

Flexion XL® Single Ply

Section 07 54 13
Copolymer-Alloy Membrane Roofing

PART 1 – GENERAL

1.1 Description

- A. Work included: all labor, materials, equipment and accessories to provide the following:
 - 1. To install a mechanically attached or fully-adhered CPA roof system including Conklin Flexion XL® DuPont® Elvaloy modified PVC membrane, flashing, accessories and other items to comprise a complete roofing system.
- B. Related work specified elsewhere:
 - 1. Protection board/leveling layer (where specified/required)
 - 2. Vapor retarded (where specified)
 - 3. Insulation
 - 4. Fasteners for insulation and membrane attachment
 - 5. Flexion XL CPA membrane
 - 6. Adhesives
 - 7. Sealants
 - 8. Roof walkways
 - 9. Metal flashing

1.2 Quality Assurance

- A. Only a contractor trained in the application of Conklin Flexion XL roofing membrane shall apply the mechanically attached or fully adhered Flexion XL roof system.
- B. The roofing contractor shall employ trained field personnel for the installation of this roof system.
- C. No deviations in the published Conklin drawing, details and specifications are permitted without the written consent of the Conklin Roofing Division.

1.3 Product Delivery, Storage and Handling

- A. All materials delivered to the job site shall be in the original unopened containers or wrappings.
- B. All materials shall be clearly identified with the manufacturer's/supplier's product identification labels.
- C. All materials must be free from damage during delivery, storage, handling and installation. Place all materials on pallets and fully protect from moisture as required by the manufacturer/supplier.
- D. Flexion XL membrane rolls shall be stored in a horizontal position, and fully protected from the elements (freezing, precipitation, direct sunlight and construction activity).

- E. Bonding adhesives shall be stored at temperature above +40°F (+5°C)
- F. All flammable materials shall be stored in a cool, dry area away from sparks and open flames. Follow precautions as outlined by material manufacturer/supplier and the product container.
- G. Any materials that are determined by the owner's representative to be damaged are to be removed from the job site and replaced with new material.
- H. **SAFETY & FIRST AID**
See product Material Safety Data Sheets or product packaging label to review safety information provided.

1.4 Job Conditions

- A. The mechanically attached or fully-adhered Flexion XL roof system specification is designed for use in structures designed to support lightweight roof assemblies. The adequacy of the structural support must be verified in writing by the owner or the owner's design professional, architect, or engineer and is the sole responsibility of the owner. Potential live loads, such as snow and ponding water, must be considered in the total load calculations.
- B. Some project conditions may require modifications to the standard specification.
 - 1. Geographical areas in wind zone four or greater as identified by Factory Mutual Loss Prevention Data Sheets 1-28.
 - 2. Where interior air pressure at the underside of the membrane is 2.6 lbs/sq.ft (0.125 kPa) or greater.
 - 3. Specific code requirements or site situations.
- C. The roofing contractor shall take care during application and storage to prevent overloading of the deck and structure.
- D. All work shall be scheduled and executed without exposing the interior building areas and its contents to the effects of inclement weather. The existing building shall be protected against all risk.
- E. Install only as much of the new roofing system as can be made weather-tight each day. This includes all related flashing work necessary to maintain a weather-tight roof system.
- F. All substrates/surfaces, which are to receive new insulation, membrane, or flashing, shall be thoroughly dry and free from dust, debris, dirt and other contaminants that may adversely affect the performance of the products and/or roof system. The roofing contractor shall provide the necessary means to rectify the substrate/surface conditions prior to the commencement of the installation of the roof system.
- G. Projects that incorporate lightweight roof deck assemblies and all reroof or retrofit projects shall have pull out tests performed by the owner's representative and/or the roofing contractor prior to the installation of the new roof system. See technical bulletin B-11-89-24 for minimum pull out values.
- H. It is the responsibility of the owner's representative and/or contractor to ensure the structural decks yield sufficient *Screw Withdrawal Test* values for the roof system being utilized.
- I. All new and temporary construction, including equipment and accessories, shall be secured in such a manner, at all times, as to preclude wind blow off or wind damage.
- J. The roofing contractor shall verify that all roof drains and soil pipes are free from obstructions. The owner or owner representative shall be notified in writing of any

obstructions. All obstructions shall be removed so that the roof drains and soil pipes are functioning properly prior to the installation of the new roof system.

- K. Temporary water stops shall be installed at the end of each day's work or as inclement weather or adverse conditions warrant. The temporary water stops shall be removed before continuing or proceeding with the next day's work. The water stops shall not adversely affect the new roof system and must be disposed of in a proper way.
- L. The contractor is cautioned that certain Conklin membranes are not compatible with asphalt, coal tar pitch, oil-based materials, cements, creosote and penta-based materials. Such materials shall not come into contact with Conklin membranes at any time. If such contact occurs, the material shall be removed and disposed of in a proper manner. The contractor should consult the Conklin Roofing Division with respect to material compatibility, precautions, and recommendations.
- M. The contractor should take necessary precautions when using solvent-based adhesives, solvents and cleaners around air in-takes. The smell of these products could be a disturbance to the building owner and occupants. It is the roofing contractor's responsibility to coordinate equipment to be turned off and on with the owner if necessary.
- N. The contractor shall follow all national, state, provincial and local safety regulations.
- O. Schedule work events to avoid the use of the newly constructed roof system as a storage area, foot-traffic surface and equipment movement area. Where such use is absolutely required, the contractor shall provide all necessary protection and barriers to segregate the work area and to prevent damage to adjacent roof areas. Both plywood and polyester felt protection or other approved barriers must be provided for all new and existing roof areas that receive traffic during construction.
- P. All new existing roofing, insulation, flashing, metal, etc. removed for construction shall be removed from the job site in a timely manner and legally transported to a legal dumping facility/site authorized to receive such materials.
- Q. Liquid materials such as solvents and adhesives shall be stored and used away from open flames, sparks and excessive heat.
- R. Contaminants, such as grease, fats, oils, solvents and chemicals shall not be allowed to come into contact with certain Conklin membranes.
- S. If any unusual or concealed conditions are discovered which may adversely affect the performance of the products or roof system, stop work immediately and notify the owner or the owner's representative. Do not proceed with the installation of the roof system until all conditions are rectified.
- T. Site clean-up, including both interior and exterior building areas that have been affected by construction, shall be completed to the owner's satisfaction.
- U. All landscaped areas affected by construction activities shall be restored to their original condition or better.
- V. All building codes must be adhered to where applicable. Where there is a conflict in design with building codes, authorities and the Conklin Flexion XL specification, the more stringent situation shall apply.

PART 2—PRODUCTS

2.1 General Requirements

- A. Acceptable materials: all components which make up the complete roofing system, including roof insulation, shall be made by, or acceptable to, the roof membrane manufacturer.

2.2 PVC Roof Membrane

- A. Acceptable manufacturers; as follows or approved equal: Conklin Company Inc., Shakopee, MN, "Flexion XL"
- B. Description: membrane composed of a high-grade PVC synthetic sheet membrane modified with DuPont Elvaloy.
- C. Physical properties: Conklin Flexion XL DuPont Elvaloy modified PVC roofing. The resulting formulation is classified as a copolymer alloy (CPA). Thickness is 60-mil.
- D. Performance properties: membrane shall meet the following minimum requirements when tested in accordance with the standard indicated.

Property	Test Method Min. Requirements	60 Mil
Thickness (inch)	ASTM D751	0.60 +/- 5%
Breaking Strength	ASTM D751	XMD - 330
	Requirement 200	MD - 370
Elongation @ Break (%)	ASTM D751	XD - 150
	XD - 15	MD - 150
	MD - 15	
Tearing Strength (lbf)	ASTM D751 45 / Tongue Method	120
Low Temperature Bend (C°)	ASTM D2136 / (-40)	Pass
Dimensional Stability (%)	ASTM D1204 / (+/- 0.5)	0

Puncture Resistance (lbf)	ASTM D4830	Pass	Pass
Water Vapor Transmission (g/h m ²)	ASTM DE96 (Method A)	0.17	0.17
Water Absorption (% max)	ASTM D570	0.24	0.24
Water Extraction (% max)	ASTM D3083	0.08	0.08
Volatile Loss (% max)	ASTM D3083	-0.45	-0.45
Accelerated Aging : Oven	ASTM D3045 7 days @ 100 C°	90 Breaking Strength (%) 90 Elongation @ Break (%) 92 Tearing Strength (%)	Same
Accelerated Aging : Water	ASTM D3045 7 days @ 70 C°	88 Breaking Strength (%) 87 Elongation @ Break (%) 85 Tearing Strength (%)	Same
Accelerated Weathering	ASTM G53	None (Cracking: 7x magnification) None (Crazing: 7x magnification) Negligible (Discoloration visual)	Same
Hydrostatic Resistance (psi)	ASTM D751	>250	Same
Fire Resistance	UL & FM	Class A**	Class A**
Wind Resistance	FM	1-90*	1-90*
Solar Reflectivity (%)	ASTM E903	83	83

* Consult Factory Mutual directory for specific details

**Consult Underwriters Laboratory building directory for specific details.

2.3 Miscellaneous Materials

- A. Conklin Spaghetti Walking Way Pad: nominal 5/16" thick non-woven pad made of flexible plastic spaghetti-like strands (available in yellow or gray).
- B. Flexion XL unsupported roll: non-reinforced Flexion XL membrane, used to detail inside and outside corner flashing, roofing protrusions and drain assemblies. Thickness 60-mil (1.5mm)
- C. PVC coated metal: 26 gauge galvanized (G-90) sheet metal laminated with a minimum 24-mil Conklin Flexion XL film, used where Conklin Flexion roofing membrane is to be welded directly to the metal flashing.
- D. Cant strips
 1. Cant strips shall be #2 quality or better and be treated for fire and rot resistance (wolmanized or osmose treated). Creosote or asphaltic treated lumber is not acceptable. Conklin Flexion XL CPA may not be directly adhered to wolmanized or osmose treated lumber.
 2. Cant strips shall conform to FM's Loss Prevention Data Sheets 1-49.
 3. Wood shall have maximum moisture content of 19% by weight on a dry weight basis.
- E. Wood boardstock
 1. When bonding directly to wood boardstock, a minimum standard ½" (13 mm) CDX exterior grade plywood, 7/16" (12 mm) oriented strand board, 7/16" flake board.
 2. Approved wood boardstock shall have maximum moisture content of 19% by

weight on a dry weight basis.

F. Vapor retarders

1. Vapor retarders for use in the mechanically attached Flexion XL roofing system shall meet identified code requirements and/or insurance requirement e.g. UL/ULC, FM, ASTM standards.
2. Vapor retarders are to be approved in writing by the vapor retarder manufacturer for their intended use.
3. Vapor retarders are to be compatible with insulation and other accessories.

G. Insulation

1. Where specified or required, insulation shall be installed over the structural deck or as a separation layer over the existing substrate and/or to obtain the desired thermal value.
2. Insulation for use in the mechanically attached Flexion XL roof system shall be Atlas AC-II isocyanurate board at a minimum of 1.5" Insulation shall meet identified code and/or insurance requirements i.e. UL, ULC, FM, ASTM, CGSB standards.
3. Insulations are to be approved in writing by the insulation manufacturer for their intended use and for use with Conklin roofing systems.
4. Insulation shall be compatible with Conklin single-ply roofing membranes. Consult the Conkling Roofing Division for chemical compatibility between insulations and Conklin Flexion roofing membrane.
5. The following insulation board is acceptable below Conklin Flexion XL roofing membrane in the mechanically attached Flexion roofing system.
 - a. A minimum 1.5" Atlas AC-II HCFC-free (zero ozone depletion potential) polyisocyanurate boardstock insulation with non-asphaltic fiberglass facers, meeting the requirements of UL, ULC, FM, CGSB standards and having a minimum compressive strength of 18 psi (125 kPa). See technical bulletin B-12-88-17 for minimum pull out values.

H. Fasteners and anchors: all fasteners shall be the same types as the metal being secured. In general, all fasteners, anchors, screws, and straps shall be of zinc or cadmium plated steel, galvanized, or stainless steel. All fasteners and anchors shall have a minimum embedment of 1" (25 mm) and shall be approved for such use by the fastener manufacturer. All fasteners shall meet Factory Mutual Standard 4470 for corrosion resistance.

I. Solvent-based adhesive: used for adhering Conklin Flexion membrane to approved substrates. **Conklin Flexion Bonding Adhesive or approved equal.**

J. **Conklin 360-S® or approved equal.**

K. Sealant: 360-S® moisture-cure urethane sealant used as a termination sealant.

L. 400g felt: non-asphaltic, non-woven geotextile fabric used as an asphalt barrier or leveling layer.

M. Trufast #12: self-tapping, corrosion-resistant fasteners, modified buttress threats, FMRC approved for use to install insulation into steel and wood decks. Corrosion resistance ASTM D-4470.

N. Trufast #14: self-tapping, corrosion-resistant fasteners, modified buttress threats, FMRC approved for use to mechanically attach Conklin Flexion roofing system into steel, concrete, and wood decks. Corrosion resistance ASTM D-4470.

O. Trufast #15: self-tapping, corrosion-resistant fasteners, modified buttress threats,

FMRC approved for use to install insulation into steel and wood decks (concrete decks require predrilled holes). Corrosion resistance ASTM D-4470.

- P. Conklin membrane plate: 20 gauge 2" (50 mm) round diameter plate used for mechanically attaching the field membrane and anchoring around penetrations such as roof drains, pitch pans, stacks, etc., galvalume coated, meets FMRC 4470 standard.
- Q. Conklin insulation plate: 26-gauge galvalume 3" (75 mm) metal plates used for mechanically attaching insulation to structural deck, meets FMRC 4470 standard.
- R. Conklin termination bar: extruded aluminum bar, center punched 8" (200 mm) O.C., used as a termination bar on vertical surfaces.
- S. Cleaner: solvent based cleaner used for removal of solvent-based adhesive from Conklin Flexion XL roofing membrane and for cleaning existing Flexion XL roofing membranes prior to hot-air welding.

2.4 Equipment (optional)

- A. Hand held hot air welding tool: equipment used to heat-weld membrane together shall be an electrically operated 110- or 220-volt hot air welding gun capable of temperatures not less than 900°F.
- B. Automatic hot air welding tools: equipment used to heat-weld membrane together shall be an electrically operated 220 volts, minimum 3,000-watt, variable speed and temperature-controlled unit.

PART 3—EXECUTION

3.1 Inspection

- A. General requirements: inspect areas to receive roofing to verify that there are no conditions which will hinder the successful installation of the membrane as specified. Necessary corrections and repairs must be completed prior to proceeding with the installation of membrane
- B. Condition of substrate: substrate to receive membranes shall be structurally sound, solid, clean, dry and free of snow and ice. Substrate which permits water ponding shall not receive membrane until condition is corrected.
- C. Completion of related work: do not proceed with work until all roof construction work has been completed, including roof edge carpentry work, roof drains, expansion joint construction, mechanical equipment curbs and rails, roof vents and other penetration work.
- D. Fastener: pull-out test will meet membrane manufacturer's requirements.

3.2 Preparation

The following general conditions apply to the structural deck that is to receive the mechanically attached Flexion roofing system.

- A. The roof deck must be structurally sound to provide support for the Flexion XL roofing system and other anticipated loads.
- B. The specifier and/or the roofing contractor shall determine the condition of the existing roof deck. Areas with deteriorated decking or showing loss of structural integrity shall be repaired and/or replaced prior to installing the new roof system.
- C. The roof deck shall be installed to the structural framing as per the applicable

building codes and/or Factory Mutual's requirements to resist all anticipated wind loading for the geographical area.

- D. Conklin requires all reroof or retrofit projects and projects that incorporate lightweight roof deck assemblies to have pull-out tests performed by the owner's representative and/or the roofing contractor prior to the installation of the new roofing system. The pull-out shall be conducted in the areas where mechanical attachment of the insulation of membrane occurs. A minimum of 10 pull-out tests is required per project under 50,000 square feet. Projects larger than 50,000 square feet shall have additional pull-out tests conducted at a rate of one pull-out test per 5,000 square feet. Approximately 60 percent of the pull-out test should be taken in the defined perimeter/corner zone of the building/roof area and 40 percent in the defined field zone of the building/roof area. See technical bulletin B-11-89-24 for minimum pull out values.
- E. The roofing contractor shall load the roof in such a manner as to eliminate the risk of deck overload due to point loading of materials and equipment.

3.3 Substrate Preparations with Removal (Reroof) of Existing Roof System

The following general apply to the substrates that are to receive the mechanically attached Flexion XL roofing system.

- A. Remove only as much of the existing roof system that can be replaced in a weather-tight condition at the end of the work period. All work shall be scheduled and executed without exposing the interior building areas and its content to the effects of inclement weather. The existing building shall be protected against all risks.
- B. The substrate shall be dry, clean, smooth, and free of flaws, sharp edges, loose and foreign material, oil and grease or other contaminants that could affect application of the membrane.
- C. The substrate shall be inspected for defects such as surface roughness, contamination, structural unsoundness or any other conditions that can affect the integrity of the roof system.
- D. The existing roofing membrane and/or insulation is to be removed to the structural deck and/or substrate as specified or required. The specified and/or the roofing contractor shall determine the condition of the existing substrate. All structural decking found to be deteriorated or unsound is to be repaired and/or replaced (refer to Section 3.02). All wet and/or deteriorated insulation substrate is to be removed and replaced as specified or required.
- E. The existing membrane flashing, deteriorated wood blocking and related metal flashing shall be removed to the substrate. All deteriorated wood blocking shall be removed and replaced as per the specifications.
- F. All materials removed from the roof system are to be disposed of by an authorized contractor at an authorized disposal or recycling facility. The removed materials shall not be stored on the job site and are to be removed from the job site on a daily basis.
- G. All substrates shall be acceptable for the installation of the mechanically attached Flexion roofing system.
- H. All structural substrate shall resist a minimum force of 175 lbs./lineal foot (2.5 kN/m) in any direction.
- I. The following substrates are acceptable for the installation of the Flexion roofing membrane:
 - 1. New insulations (refer to Section 2.03G) that are recommended by their manufacturer for use in a mechanically attached Flexion XL roof system.

2. Existing insulations (refer to section 2.03G) that are recommended by their manufacturer for use in a mechanically attached roofing system and are overlaid with an approved insulation or leveling/separation sheet.
 3. Structural steel decks (refer to Section 3.02) overlaid with leveling layer of insulation (refer to Section 2.03G) or exterior-grade gypsum boards meeting ASTM standards.
- J. The following substrates are acceptable for the installation of the Flexion XL roofing membrane.
1. The polyisocyanurate insulation with fiberglass facer, free of bitumen or other contaminants. The insulation is to be mechanically attached with an appropriate fastener and plate at the rate of 1 per 2 square feet (1 per 0.2m²).
 2. New ½" (13 mm) 'C' or better grade exterior plywood, 7/16" (12 mm) oriented strand board, 7/16" flakeboard or ½" free of bitumen or other contaminants. The approved board is to be mechanically anchored with an approved fastener at the rate of 1 per 2 square feet (1 per 0.2m²)
 3. New 24 gauge (or higher) galvanized metal flat stock, free of bitumen or other contaminants. The metal is to be anchored as per SMACNA latest edition.
 4. Precast or poured concrete, with steel float finish, free of bitumen or other contaminants.

3.4 Substrate Preparations without Removal (Retrofit) of Existing Roof System

- A. It is the sole responsibility of the owner's representative, roofing contractor and professional roof designer to ensure the condition of the roof assembly is suitable for the installation of a retrofitted roof system that utilizes the mechanically attached Flexion XL roofing system. All previous general conditions relating to approved insulations, substrates and structural roof decks, etc. shall apply. Retrofitting over coal tar pitch roofs require special considerations.
- B. The existing roof systems shall be inspected for defects such as surface roughness, contamination, structural unsoundness or any other conditions that can affect the integrity of the roof system.
- C. The owner's representative, roofing contractor and professional roof designers shall conduct building physics analysis to ensure the proper dew point placement and that condensation will not occur within the new retrofitted roof assembly.
- D. The owner's representative, roofing contractor and professional roof designer shall conduct the appropriate engineering study to determine that the existing structure and structural decking will withstand all anticipated dead and live loads.
- E. The owner's representative, roofing contractor and professional roof designer shall determine the existing roof system is free from moisture and will not affect the integrity of the new roof system. Thermographic scans with an infrared camera (or other non-destructive test methods) may be used to determine the areas of wet/damp insulation and roof membrane. Also, destructive testing such as core sampling should be taken to verify the existing condition
- F. All wet/damp deteriorated insulation is to be removed and replaced as specified and/or required. An authorized contractor shall remove all insulation from the existing roof system from the job site to an authorized disposal or recycling facility on a daily basis.
- G. All existing loose aggregate is to be removed from the roof surface/substrate by means of power scraping, power brooming or vacuuming. All existing aggregate is to be removed from the job site by an authorized contractor to an authorized disposal or recycling facility on a daily basis.

- H. Scarify and remove accumulations of bitumen or other irregularities to produce a relatively smooth roof surface/substrate.
- I. All blisters, ridges and irregularities are to be removed and repaired to match the original construction or as specified.

3.5 Cant Strip Installation

- A. Install cant strip at the perimeter of the entire roof and around roof projections and penetrations as specified and shown on the detail drawings.
- B. Cant strip shall be anchored to resist a minimum force of 175 lbs./lineal foot (2.5kN/m) in any direction. Fastener spacing shall be a maximum of 2 feet (600 mm) on center. Fasteners shall be installed within 6" (150 mm) of each end. Spacing and fastener embedment shall conform to Factory Mutual Loss Prevention Data Sheet 1-49.
- C. Thickness shall be required to match substrate or insulation height.
- D. Any existing woodwork that is to be reused shall be firmly anchored in place and shall resist a minimum force of 175 lbs./lineal foot (2.5 kN/m) in any direction and be free from rot. Only reusable woodwork shall be left in place, and all other woodwork shall be removed.

3.6 Vapor Retarder Installation (where specified)

- A. Interior and/or exterior climatic conditions (ambient temperature, relative humidity, and internal air pressure) may warrant the use of a vapor retarder/air barrier in the building construction. It is the responsibility of the design professional, based on geographical location and the intended use of the building, to determine the type and location of the required vapor retarder/air barrier.
- B. Conklin recommends that consideration should be given for the use of a vapor retarder to protect the integrity of the insulation, when the interior relative humidity is 45 percent or greater, the outside mean average January temperature is below 40°F (5°C) and/or special situations such as freezers and high humidity environments.
- C. A vapor retarder may also perform as an air barrier with the building envelope. Conklin recommends that consideration should be given to the installation of an air barrier for building subject to high internal air pressures such as airplane hangars or structures with sufficient openings in the wall area directly below the structural roof deck to adjust the wind uplift pressures.
- D. Install the vapor retarder as per the manufacturer's current published specifications to ensure the continuity of the vapor retarded with the roof system. The vapor retarder may be loose laid over the approved substrate.

3.7 Insulation Installation

- A. Insulation shall be installed according to the insulation manufacturer's current published specifications for use with a mechanically attached roof system.
- B. Insulation shall be laid over an acceptable substrate (deck, vapor retarder, existing insulation or existing roofing membrane), parallel to the deck (where applicable). Install insulation in parallel courses, butted together in moderate contact without gaps and staggered end joints. Provide full support at ends. When multiple layers

of insulation are specified the subsequent layers shall be installed with joints offset from the underlying layer.

- C. Insulation shall be attached to the approved substrate by the following methods.
1. Mechanically attachment:
 - a. Fasteners and insulation plates shall meet Factory Mutual Standard 4470 for corrosion and wind uplift resistance.
 - b. Insulation shall be mechanically attached to an approved substrate as per Factory Mutual Approved Guide (latest edition). Fastening rates increase in the perimeter zone and in the corner zone, by 50 percent and 75 percent respectively compared to the field fastening rates.
 - c. The placement of the fasteners and plates shall be as per Factory Mutual fastening patterns.
 - d. The fasteners shall be installed using tools with a depth locator as recommended by the fastener manufacturer. Fasteners must penetrate the structural deck as per Factory Mutual.
 - e. Structural decks other than 5/8" (59 mm) plywood, 2" (50 mm) wood, 22 gauge steel. Precast, pre-stressed or poured concrete decks consult the Conklin Building Products Division.
 - f. Note:
 - (i) Fasteners shall penetrate the underside of a steel deck a minimum of ½" (13 mm)
 - (ii) Fasteners shall penetrate the underside of the plywood deck a minimum of ½" (13 mm)
 - (iii) Fasteners shall penetrate the wood deck a minimum of 1" (25 mm)
 - (iv) Fasteners shall penetrate poured structural, precast, pre-stressed concrete decks a minimum of 1" (25 mm)
 2. Hot asphalt or low-rise foam attachment:
 - a. Insulation attached with hot asphalt or low-rise foam shall be installed according to Factory Mutual, insulation manufacturer's and deck manufacturer's current published specifications.
 - b. The structural deck/substrate shall be prepared for the installation of the new insulation as per the insulation manufacturers and deck manufacturer's current published specifications.
 - c. The insulation shall be set into a continuous coating of type III steep asphalt or approved low-rise foam adhesive. Refer to the manufacturer's current published specifications for application rates. Additional securement may be required at the perimeters and corner zones.
 - d. Insulation shall be a maximum of 4 ft. x 4 ft. (1.2 m x 1.2 m) in size.
 - e. Insulation shall be fully adhered to the prepared structural deck/substrate.
 - f. The top surface of any insulation substrate that has been contaminated with asphalt shall be removed and replaced prior to the application of Flexion XL.
 3. Adhesive attachment:

- a. Insulation attached with adhesive shall be installed according to FM Global and insulation manufacturers, adhesive manufacturers and deck manufacturer's current published specifications
- b. Consult the Conklin Building Products Division for project specific requirements when adhesive attachment method is to be utilized.

3.8 Flexion XL Roofing Membrane Installation

- A. The surface of the insulation or substrate shall be inspected prior to installation of the Flexion XL roofing membrane. The substrate shall be swept clean, dry and smooth with no excessive surface roughness and contamination. All fasteners (where applicable) shall be properly seated and flush. Any damaged, broken, contaminated or delaminated insulation boards are to be removed and replaced.
- B. Mechanically attached:
 1. Determine layout of membrane and, where possible, overlap seams in the direction of water run-off.
 2. Over the properly installed and prepared substrate surface, unroll the Flexion XL roofing membrane and draw tight without folds or wrinkles. Adjacent sheets shall be overlapped 5" (125 mm). End laps shall be overlapped 3" (75 mm).
 3. Flexion XL membrane shall be mechanically attached as per Factory Mutual Approval Guide (latest edition). Fastener and disc are to be installed centered along the line marked approximately 1.5" from the edge on the membrane sheet leaving approximately 0.5" outside the disc (refer to Conklin detail 1.1 & 1.2). Adjacent sheets shall overlap the underlying sheet along the line marked approximately 5" from the edge, leaving approximately 2.5" between the line and the disc. Hot air weld the seam area as per the appropriate seam welding techniques (refer to Section 3.09).
 4. The fastener and disc are to be placed within the seam at the rate as determined by Factory Mutual and/or the design professional.
 5. The fasteners shall be installed using tools with a depth locator as recommended by the fastener manufacturer. Fasteners must penetrate the structural deck as per Factory Mutual and the fastener manufacturer.
- C. Solvent-based adhesive: Pliobond9752
 1. Over the properly installed and prepared substrate surface, the adhesive shall be applied using approved solvent resistant paint rollers. The adhesive shall be applied at a rate of approximately 50-70 Sq./gal. (2.0-2.5 Dry Mills coated both sides) depending upon the surface of the substrate. The adhesive shall be applied in smooth, even coatings with no globs, puddles, or similar irregularities. Only an area that can be covered completely in the same day's operations shall be coated with adhesive. The adhesive on the substrate surface shall be allowed to dry completely prior to installing the membrane.
 2. Notes:
 - a. Drying time increases with cooler temperatures and high humidity conditions (allow the adhesive to dry a minimum of 1 hour and a maximum of 3 hours).
 - b. The contractor shall calculate the amount of adhesive used per square, and shall count the number of pails of adhesive used per area per day to verify that they are conforming to the specified adhesive rate.
 3. When the adhesive on the substrate is dry unroll the Flexion XL® PVC/CPA membrane and draw tight without folds or wrinkles. After

membrane, >2 of the sheets length shall be pulled back and the underside shall be evenly coated with solvent-based adhesive at a rate of 50-70 Sq.'/gal. (2.0-2.5 Dry Mills coated both sides) While the adhesive is tacky (produces strings when touched with a dry finger), the coated membrane shall be rolled carefully onto the previously coated substrate to avoid wrinkles. Do not allow adhesive on the underside of the membrane to dry completely. Ambient temperature, humidity, and personnel will determine the amount of membrane that can be coated with adhesive before applying to substrate. No adhesive shall be applied in lap areas that are to be hot-air welded or adjacent sheets. The remaining non-adhered field sheet shall be pulled back and the procedure shall be repeated.

4. The adhered membrane sheet shall be pressed firmly into place with a weighted foam-covered lawn roller, rolling in two directions to promote 100% adhesion.
5. All sheets shall be applied in the same manner, lapping all sheets as required by welding techniques. Adjacent sheets shall be overlapped 3" (75 mm) and hot-air welded. All

D. Water-based adhesive: Pliobond 7008

1. Water Based Adhesive is not to be used on slopes greater than 2:12.
2. Over the properly installed and prepared substrate, position the Flexion XL[®] PVC/CPA membrane with approximately 15 feet of the sheet unrolled to ensure correct alignment. Apply the water-based adhesive in front of the aligned membrane. Apply adhesive by roller to the substrate at the specified coverage rate. The adhesive shall be applied at a rate of approximately 165-175 Sq.'/gal. depending upon the surface of the substrate. For vertical attachment, both substrate and membrane can be coated, at a total rate equal to the specified coverage rates. The adhesive shall be applied in smooth, even coatings with no globs, puddles, or similar irregularities. Only an area that can be covered completely in the same day's operations shall be coated with adhesive. The formation of film on the surface of the adhesive shall not be allowed to occur.
3. Note:
 - a. The contractor shall calculate the amount of adhesive used per square, and shall count the number of pails of adhesive used per area per day to verify that they are conforming to the specified adhesive rate.
 - b. Do not install water based adhesive when the temperature during the application and curing time (24 to 48 hours) will be at or below 40 degrees Fahrenheit.
4. While the adhesive is still wet carefully unroll the membrane into the adhesive without folds or wrinkles. The adhesive shall be continually applied and the membrane rolled out until the entire roll has been set in adhesive. The remaining 15 feet of the non-adhered field sheet shall be pulled back and the procedure shall be repeated.
5. The adhered membrane sheet shall be pressed firmly into place with a weighted foam-covered lawn roller, rolling in two directions to promote 100% adhesion.
6. All sheets shall be applied in the same manner, lapping all sheets as required by welding techniques. Adjacent sheets shall be overlapped 3" (75 mm) and

hot-air welded. No adhesive shall be applied in lap areas that are to be hot-air welded.

- E. Perimeter and corner zones:
1. The perimeter and corner zones are defined as per Factory Mutual 1-28 and 1-29 Loss Prevention data sheets. Refer to Factory Mutual 1 – 28 and 1 – 29 to determine perimeter and corner zone dimensions and the appropriate wind exposure classification.
 2. Flexion XL 3-foot-wide perimeter sheets are to be installed parallel with the entire perimeter of the building/roof area. Adjacent sheets shall be overlapped 5" (125 mm). End laps shall be overlapped 3" (75 mm).
 3. A minimum of two, Flexion XL 3-foot-wide sheets are required to be installed on all projects.
 4. Corner zones require an increased rate of mechanical attachment compared to the perimeter zones. Refer to Flexion detail MF 10-1, MF 10-2, for typical perimeter and corner sheet layout.

3.9 Welding of Seams

- A. General
1. Seam areas are to be dry, clean and free of dirt, debris and adhesives.
 2. Flexion XL membrane seams are to be thermally fused (hot air welded).
 3. Lap membrane seam joints 5" (125 mm).
 4. Welding equipment shall be designed and manufactured for the purpose of thermally fusing PVC/CPA roof membranes.
 5. Prior to commencement of welding process, determine correct temperature setting and welding speed of equipment using test samples.
- B. Hand welding
1. Perform hand welding in the following stages
 - a. Warm up hot-air welding equipment as recommended by the equipment manufacturer.
 - b. Position Flexion XL membrane in place with specified seam joint overlaps.
 - c. Pre-weld back edge, with narrow continuous weld approximately 0.5" (12 mm) wide to prevent heat loss during the final welding stage. The pre-weld shall be positioned, from the outside edge, the distance of the width of the nozzle used from the welding application.
 - d. Finally, weld the outside edge with a continuous seam of approximately 0.5" to 1" (12mm to 25mm) width. Insert the nozzle into the seam at a 45-degree angle. When the membrane begins to flow and the proper welding temperature is reached, position the hand roller perpendicular to the nozzle and press adequately to achieve a continuous homogeneous weld. Move the hot-air welder and roller in a smooth continuous motion along the seam. Welding seam ranges from 1 ft. to 2 ft. (0.30 m to 0.60 m) per minute. For straight laps use a 1.5" (40mm) wide nozzle. For corners and compound connections use a 0.75" (20mm) wide nozzle. Remove residue collected at nozzle with steel wire brush prior to start of new seam.
- C. Automatic (machine) welding
1. Perform automatic welding in the following stages
 - a. Warm up hot-air welding equipment as recommended by the equipment manufacturer.
 - b. Position Flexion XL membrane in place with specified seam joint overlaps.

- c. Perform machine welding as per welding machine instructions. Continuously guide and supervise welding machine during entire welding process. Remove membrane residue collected at nozzle with steel wire brush at least every 100 ft. (30.5 m) and prior to the start of a new seam. Welding speed ranges from 8 ft. to 10 ft. (2.40 m to 3.00 m) per minute. Local codes for electrical supply, grounding, over-current protection and other related items are to be observed. Typically, automatic welding machines require 218 to 230 volts at 30 to 40 amps. The use of a portable generator (minimum output of 6500W) or direct wiring is the recommended power supply.
- D. Quality control of seams
 - 1. Visual evidence of proper welding is minor smoke development during the welding process, shiny membrane surface and an uninterrupted bead of thermally fused material from the underside of the top membrane.
 - 2. The roofing contractor shall physically check all completed hot-air welded seams after cooling for continuity of weld using a seam probe or a flat #3 screwdriver. Any voids or deficiencies in the membrane seaming are to be repaired by the end of the work period. Apply an additional layer of membrane extending 3" (75 mm), in all directions, beyond the area to be repaired and hot air weld using the hand welding procedures.
 - 3. The roofing contractor at various seam locations shall make on-site physical evaluation of hot-air welded seams daily. 2" (50 mm) wide cross-sectional samples shall be taken three times a day (minimum) through completed seams. Correct welds display failure from shearing of the membrane prior to separation of the weld. The contractor shall patch each test cut. Any voids or deficiencies in the membrane seaming are to be repaired by the end of the work period. Apply an additional layer of membrane extending 3" (75 mm), in all directions, beyond the area to be repaired and hot air weld using the appropriate welding procedures.

3.10 Mechanically Attached Installation

- A. Install disc at all transitional changes between the field (horizontal) and flashing (vertical) surfaces (e.g., perimeters, walls, curbs, etc.).
- B. Position the disc approximately 0.5" (12 mm) from the flashing surface on the field surface.
- C. Disc shall be spaced, at all perimeters, as per the perimeter zone spacing requirements.
- D. Disc shall be spaced a maximum 12" (300 mm) on center at all other transitions. All fasteners shall be approved and penetrate into the structural substrate the appropriate depth.
- E. Note:
 - 1. Fasteners shall penetrate the underside of a steel deck a minimum of ½" (13 mm).
 - 2. Fasteners shall penetrate the underside of a plywood deck a minimum of ½" (13 mm).
 - 3. Fasteners shall penetrate wood deck a minimum of 1" (25 mm)
 - 4. Fasteners shall penetrate poured structural, precast and pre-stressed concrete decks a minimum of 1" (25 mm).
 - 5. Consult the Conklin Building Products department for fastener penetration depths

- F. on all other structural decks.
- G. Install disc at all penetrations (e.g. drains, vent pipes, etc.) on the roof surface spaced a maximum of 6" (150 mm) O.C. with a minimum of four fasteners per penetration.
- H. Position the disc approximately 1" (25 mm) from the edge of the flange (if applicable), penetration on the horizontal (field) membrane.
- I. Mechanically fasten the disc with approved fasteners, penetrating into the structural substrate the appropriate depth.
- J.

3.11 Flexion XL Membrane Flashing Installation

A. General:

1. All Flexion XL flashing membrane shall be installed concurrently with the roof membrane as the job progresses. No temporary flashing shall be allowed without the prior written approval of the owner's representative.
All areas where water enters the new roof system shall be inspected and the affected area shall be removed and replaced. Flexion membrane flashing shall be installed on compatible, dry, smooth, and solvent resistant surfaces.
2. All Flexion XL flashing shall extend a minimum of 8" (200 mm) above the horizontal (field) surface level unless previously accepted by the owner's representative.
3. The Flexion XL flashing shall extend 5" (125 mm) onto the field roofing membrane and shall extend 2.5" (63 mm) beyond the edge of the barbed disc. The Flexion XL field and flashing membrane shall be hot air welded together to form a monolithic membrane.
4. Flexion XL flashing membrane shall be terminated according to Conklin recommended details. All termination bars shall be fastened a minimum of 12" (300 mm) O.C.

B. Fully adhered flashing:

1. Over the properly installed and prepared substrate surface, water-based or solvent based adhesive shall be applied using approved paint rollers. The adhesive shall be applied at the approved coverage rates noted previously in sections 3.08 c. 1 (Solvent Base) or 3.08 d. 2 (Water Based). The adhesive shall be applied in smooth, even coatings with no globs, puddles, or similar irregularities. Only an area that can be covered completely in the same day's operations shall be coated with adhesive. The adhesive on the substrate surface shall be allowed to dry completely prior to installing the membrane.
2. Notes: (Solvent Based Adhesive)
 - a. Drying time increases with cooler temperatures and high humidity conditions (allow the adhesive to dry a minimum of one hour and a maximum of three hours).
 - b. The contractor shall calculate the amount of adhesive used per square, and shall count the number of pails of adhesive used per area per day to verify that they are conforming to the specified adhesive rate.
3. On a dry surface, the Flexion XL flashing membrane is cut to a workable length, approximately 6 ft. (1.83 m), and the underside shall be evenly coated with solvent-based adhesive at a rate of 50-70 Sq./gal. (2.0-2.5 Dry Mills) While solvent-based adhesive is tacky (produces strings when touched with a dry finger), the coated membrane shall be rolled carefully onto the previously coated substrate to avoid wrinkles. Do not allow adhesive on the underside of the Flexion XL membrane to dry completely. Ambient temperature, humidity, and

personnel will determine the amount of membrane that can be coated with adhesive before applying to substrate. No solvent-based adhesive shall be applied in lap areas that are to be hot air welded to flashing or adjacent sheets. All sheets shall be applied in the same manner, lapping all sheets as required by welding techniques. Adjacent sheets shall be overlapped a minimum of 3" (75 mm) and hot air welded.

4. The Flexion XL adhered flashing membrane sheet shall be pressed firmly into place with a hand roller.
5. Flexion XL flashing membranes shall be fully adhered to solvent-resistant substrates. All interior and exterior corners and miters shall be cut and hot-air welded into place. No bituminous elements shall be in contact with the Flexion XL membrane.

3.12 Flexion XL/Yellow Spaghetti Walkway Installation

- A. General:
 1. Walkways shall be provided for regular maintenance of rooftop equipment and for roof areas subject to foot traffic.
- B. Installation of Flexion XL/Yellow Spaghetti Walkway Pad:
 1. The Flexion XL membrane shall be clean, dry and free of all debris.
 2. Apply either 3' x 4' pads or 3' x 25' rolls of walkway pad in the designated areas. Adhere in place with Conklin 360-S urethane sealant in the corners (25' roll should be adhered every 3').

3.13 PVC Metal Edge Flashing Installation

- A. PVC metal flashing shall be installed concurrently with the roof membrane as the installation progresses.
- B. All fabrication practices and installation procedures shall conform to the applicable requirements of the following, unless otherwise specified and/or detailed:
 1. Sheet Metal and Air Conditioning National Association Inc. (SMACNA –latest edition)
 2. Factory Mutual Loss Prevention Data Sheet 1 – 49 (or latest edition)
 3. National Roofing Contractors Association (NRCA –latest edition)
 4. Canadian Roofing Contractors Association (CRCA – latest edition)
- C. PVC metal flashing shall be mechanically anchored into wood blocking with approved fasteners. Two rows of fasteners shall be installed 4" (100 mm) O.C. and staggered. The fasteners shall penetrate the wood blocking a minimum of 1" (25 mm).
- D. PVC metal flashing shall be installed on a 24-gauge galvanized metal starter strip and the face of the flashing shall be "S-Locked."
- E. Hot-air weld Flexion XL flashing membrane, 4" (100 mm) wide by the width of the flange, over the joint in the PVC metal.
- F. Hot-air weld Flexion XL flashing membrane, a minimum of 4" (100 mm) from the outside edge of the PVC metal flashing, onto the Flexion XL field membrane.
- G. Check all seams with a seam probe or a #3 rounded screwdriver.

3.14 Metal Flashing Installation (other than PVC)

- A. All fabrication practices and installation procedures shall conform to the applicable requirements of the following, unless other specified and/or detailed:
 1. Sheet Metal and Air Conditioning National Association Inc. (SMACNA –latest edition)

2. Factory Mutual Loss Prevention Data Sheet 1-49 (or latest edition)
3. National Roofing Contractors Association (NRCA –latest edition)
4. Canadian Roofing Contractors Association (CRCA – latest edition)

3.15 Tie-ins

A. Temporary

1. Temporary tie-ins shall be installed at the end of each work period and when work is postponed due to inclement weather conditions. The staggered insulation substrate shall be straightened using partial filler pieces on insulation loose laid. The new Flexion XL field membrane shall be sealed to the deck and/or substrate (creating a water cut-off) to prevent water migration from the existing roof system into the new roofing system. The edge of the membrane shall be sealed in a continuous application of butyl tape, polyurethane foam froth pack or other acceptable methods. When work resumes the contaminated Flexion XL field membrane shall be cut out. All sealant, contaminated membrane, insulation fillers, etc. shall be removed from the work area and disposed of off-site. None of these materials shall be used in the new work. All temporary tie-ins shall be constructed to provide a 100 percent watertight seal.

B. Permanent

1. Permanent tie-ins shall be installed at the end of the project or as dictated by construction scheduling. Permanent tie-ins shall incorporate a water cut-off to prevent water migration from the existing roof system into a new roofing system.

3.16 Completion

- A. Upon completion, the contractor shall clean up and remove from the job site all rubbish, debris and surplus materials.
- B. The owner, owner's representative and roofing contractor shall review the completed work and document all deficiencies. Upon inspection of the completed roof system the contractor shall promptly correct all documented deficiencies and non-compliance with Conklin's current published specifications and details.

3.17 Maintenance

- A. Maximization of the anticipated life cycle of a roofing system is dependent upon the successful implementation of an appropriate maintenance program. Conklin requires the building owner to implement an inspection and maintenance program when using the optional Conklin warranty program. Conklin encourages a maintenance program on all applications to ensure longevity of the roofing system.

END OF SECTION

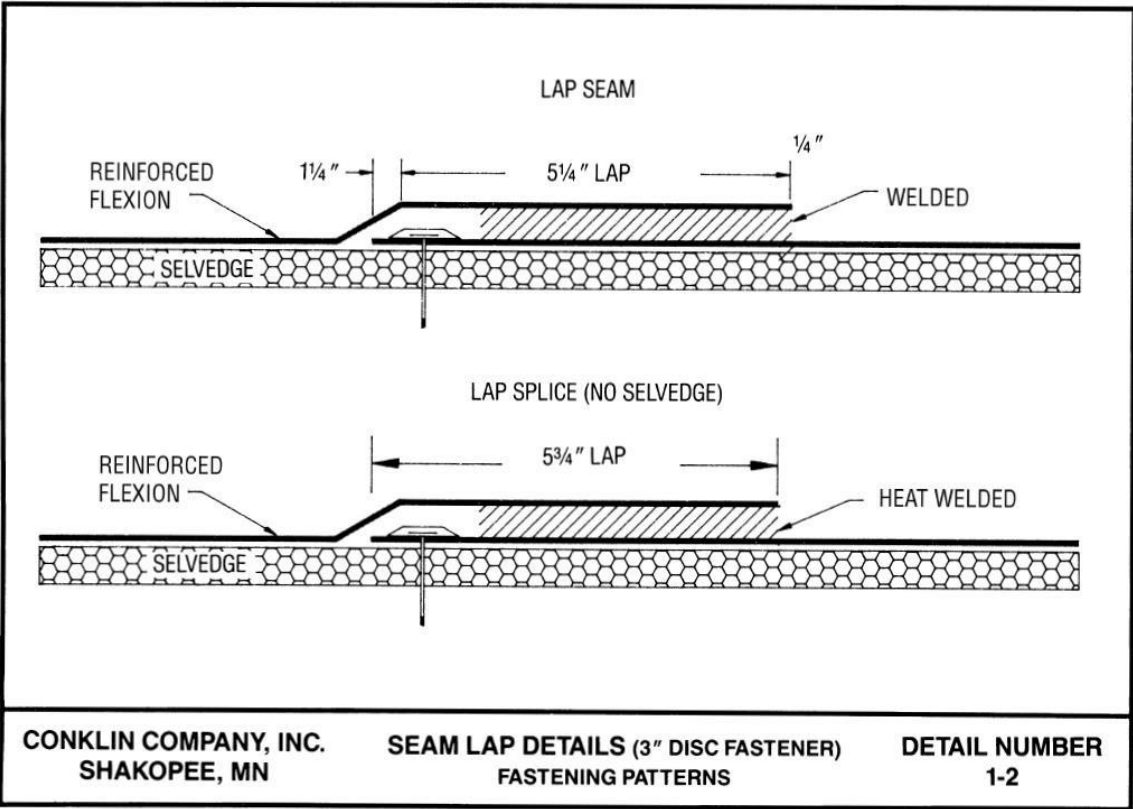
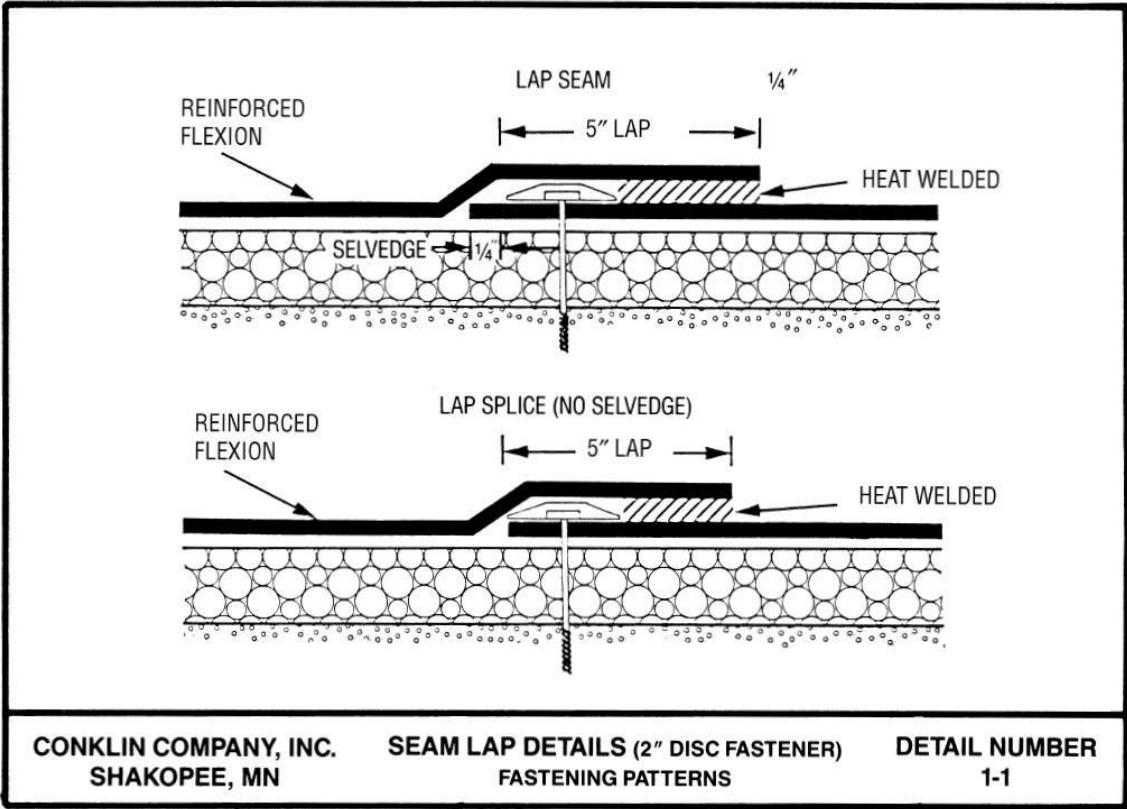

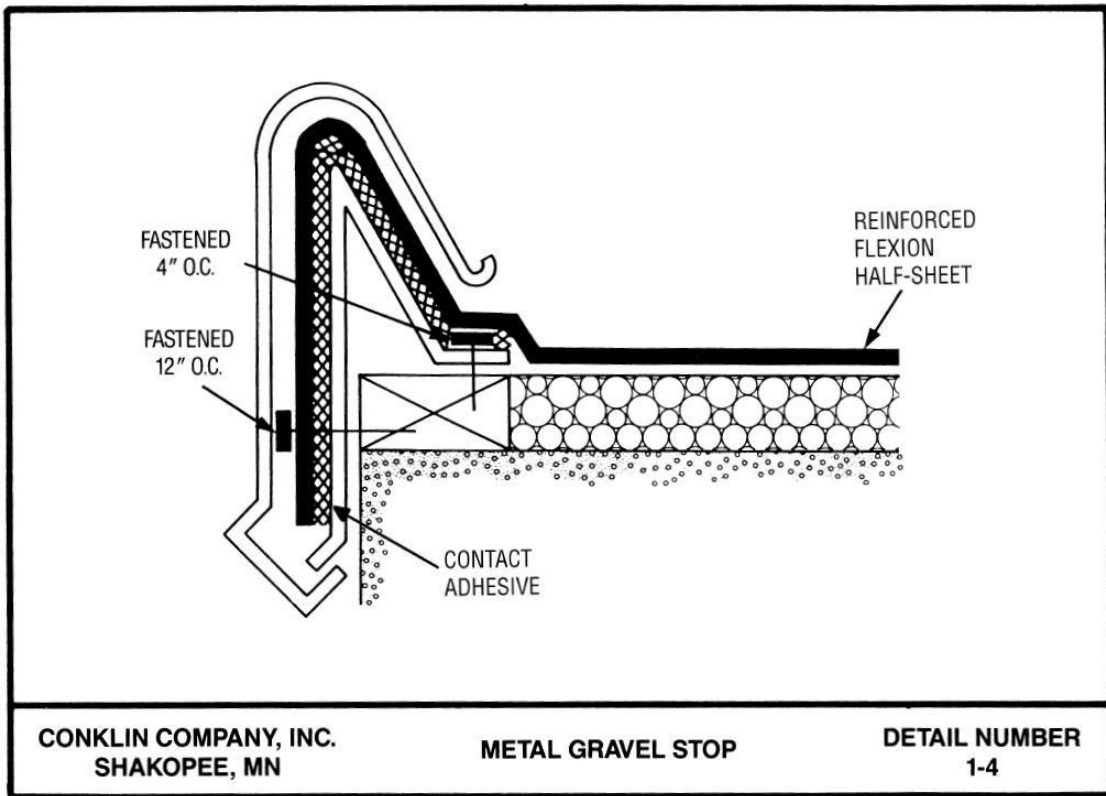
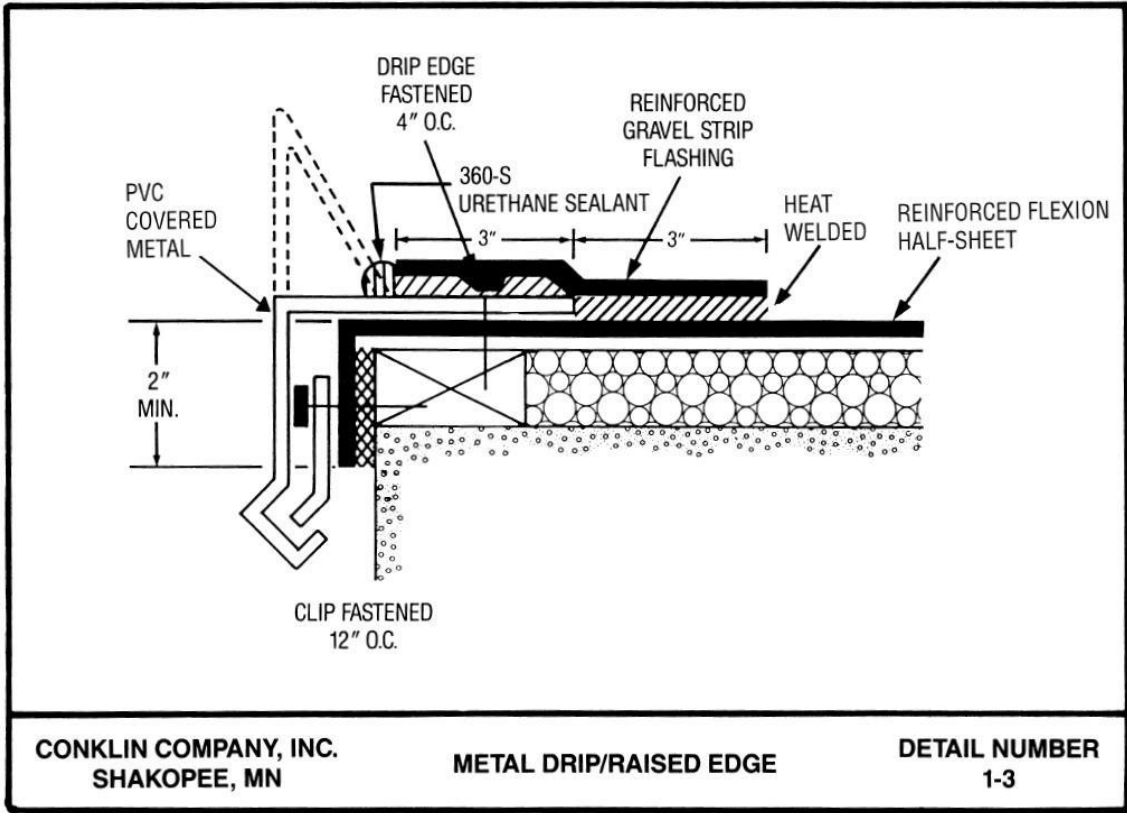

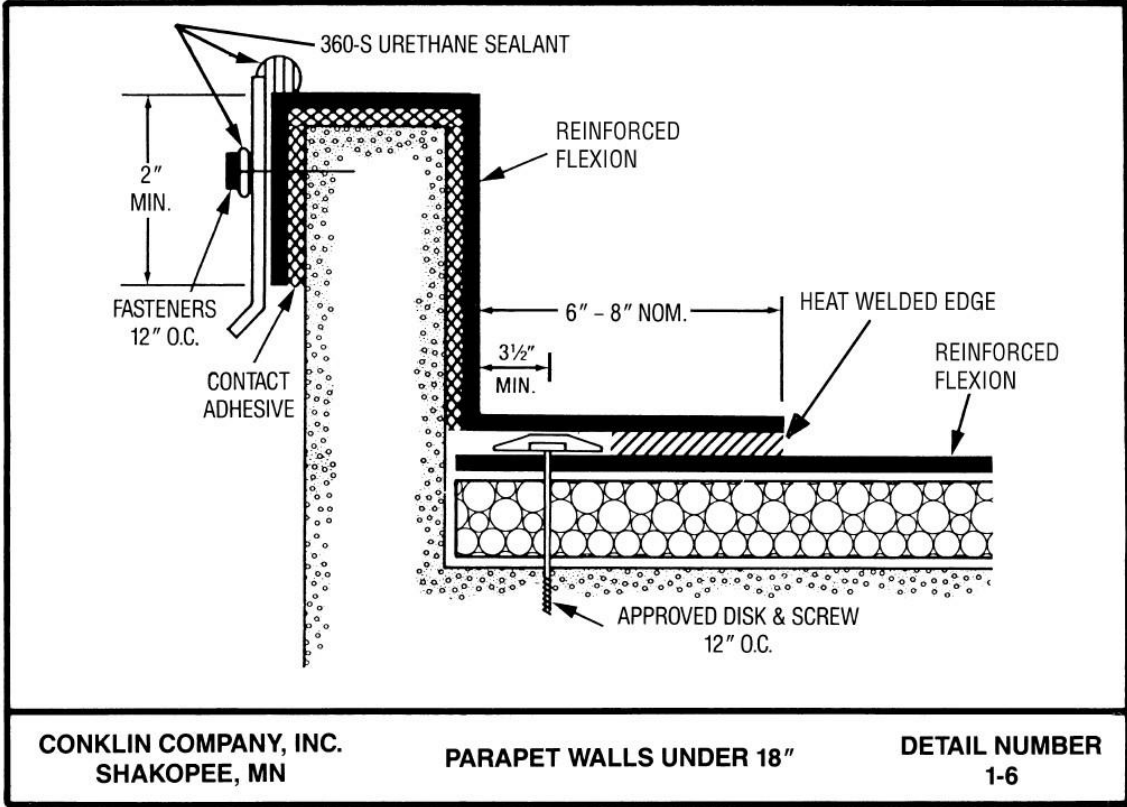
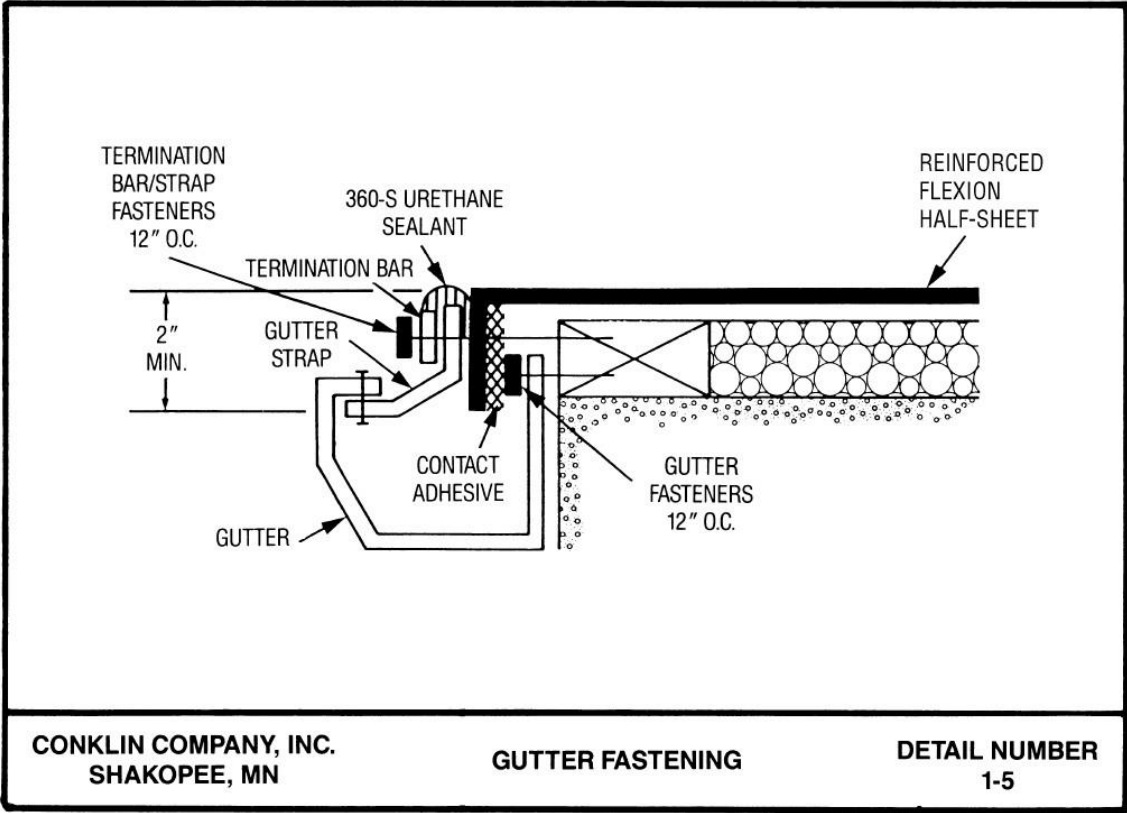

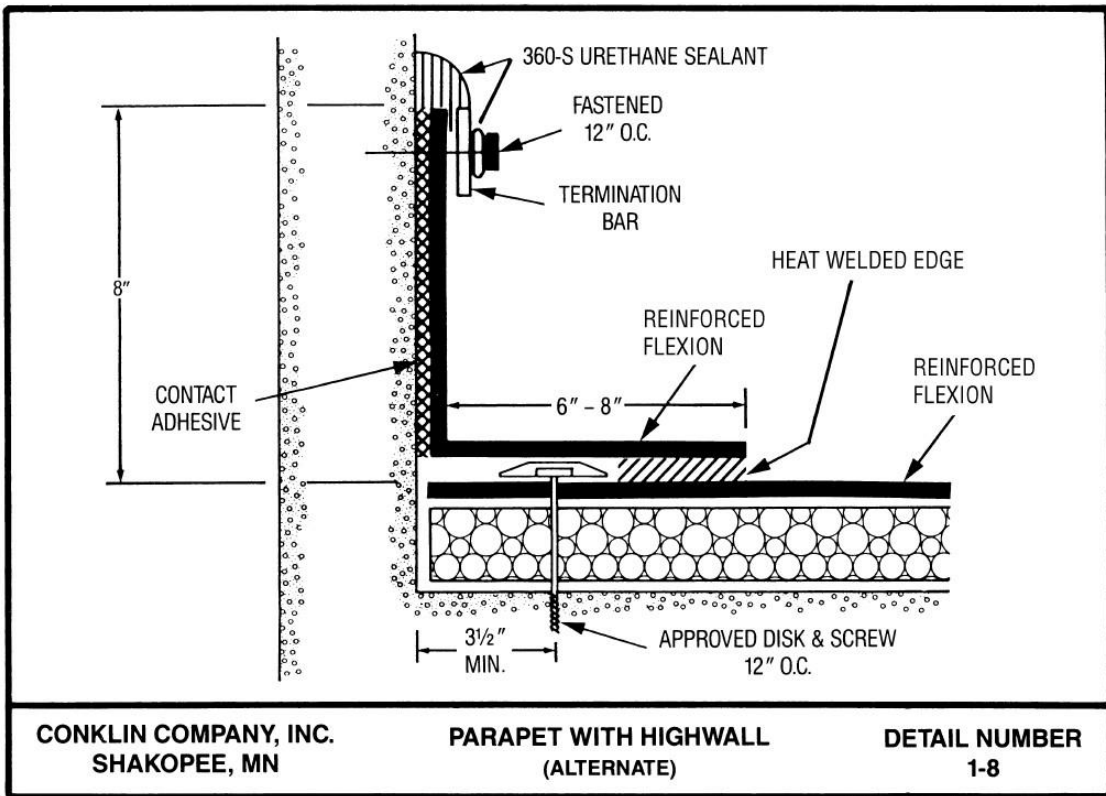
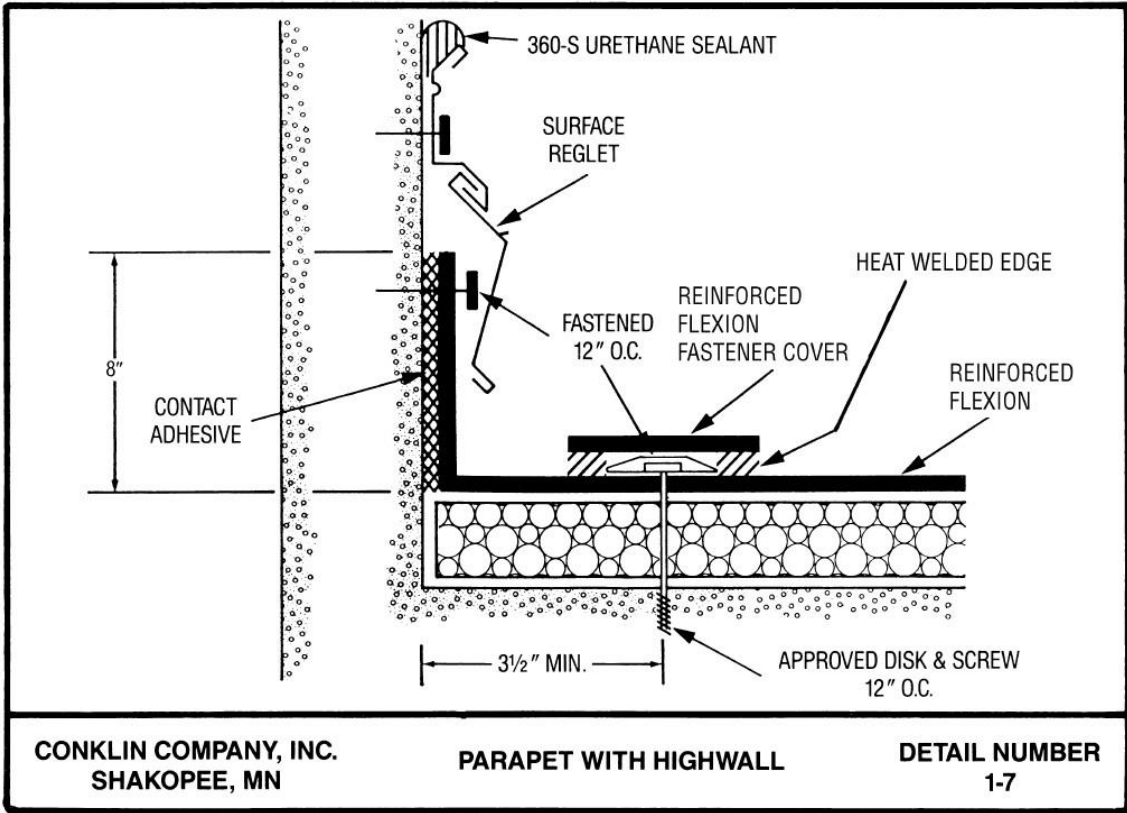

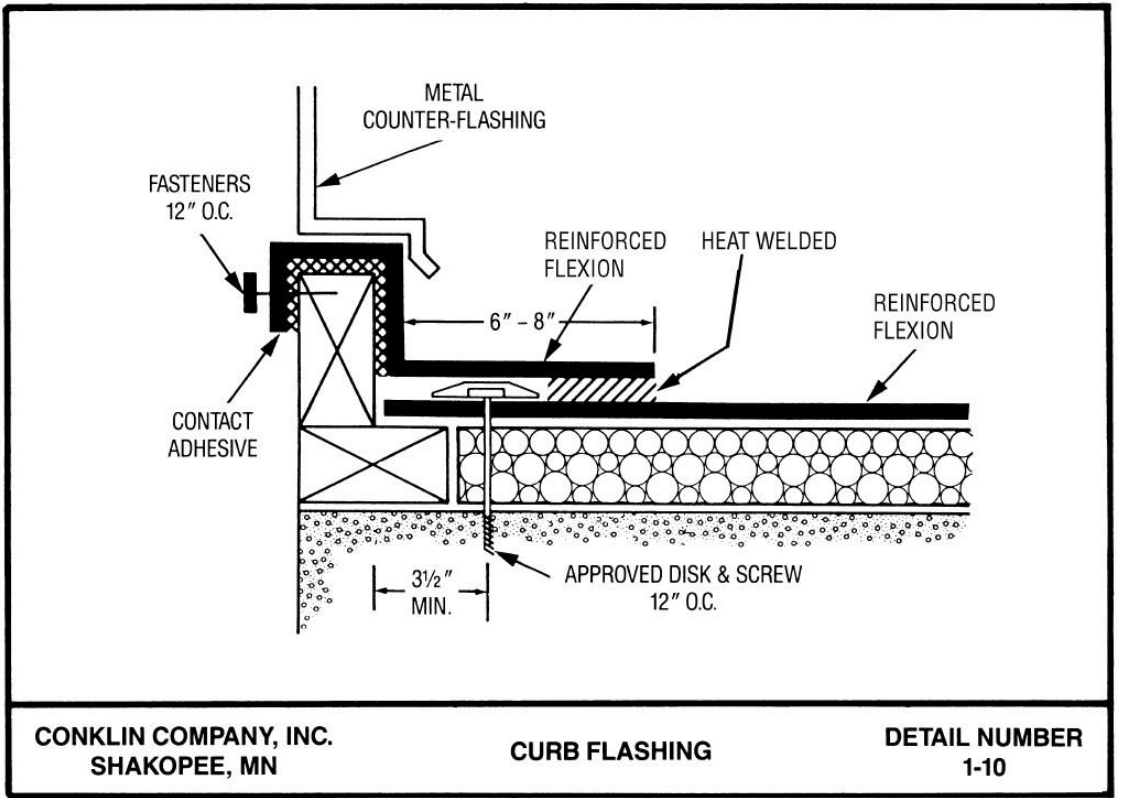
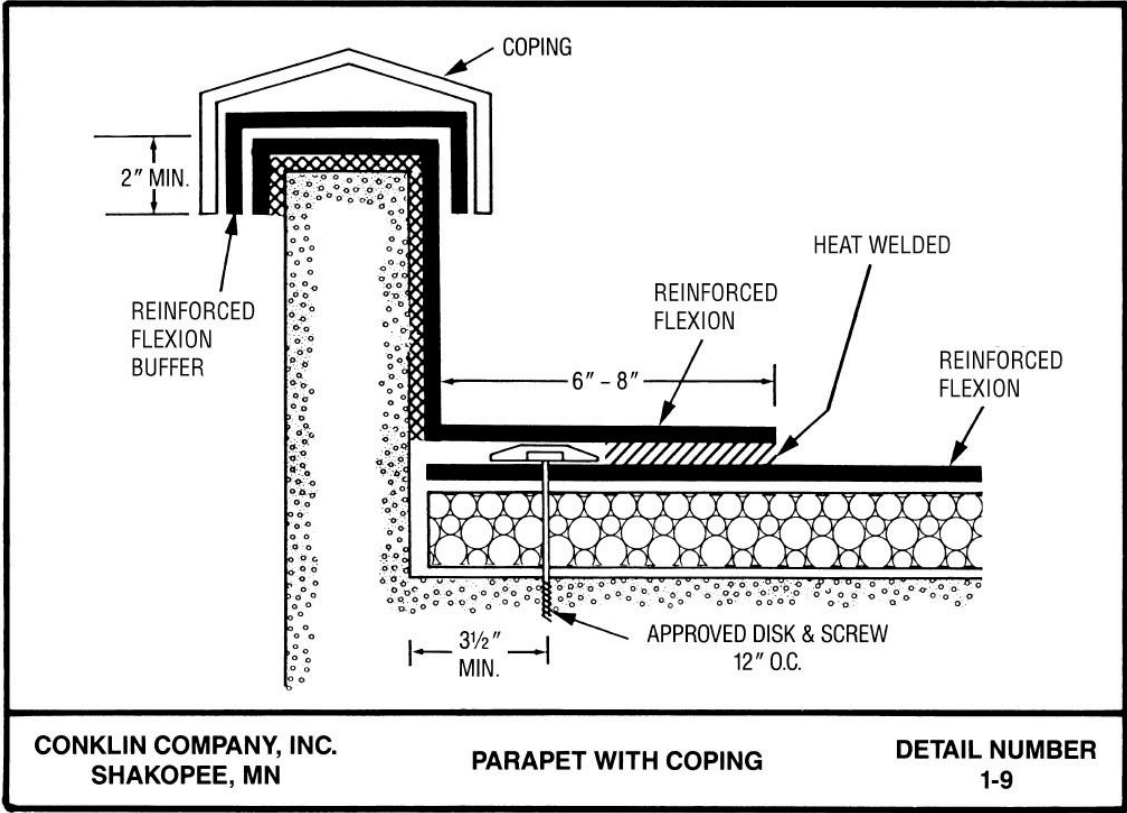

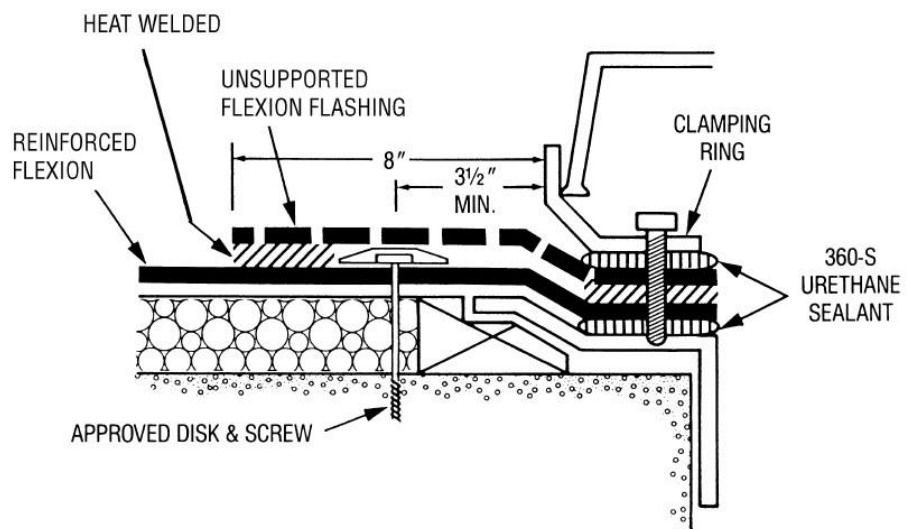

CONKLIN COMPANY, INC.
SHAKOPEE, MN

ROOF DRAIN

DETAIL NUMBER
1-11

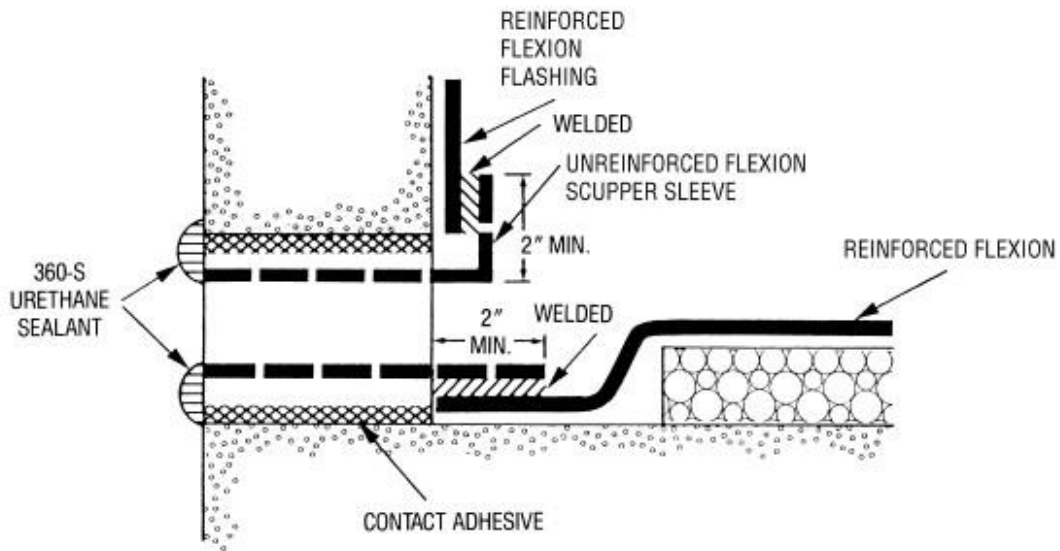
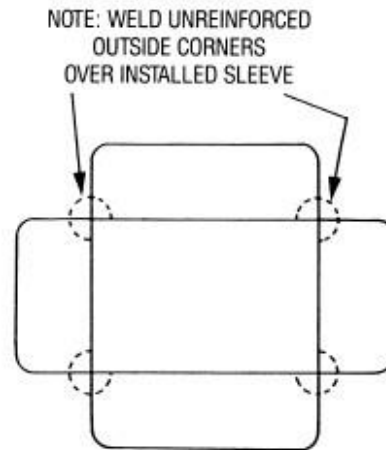
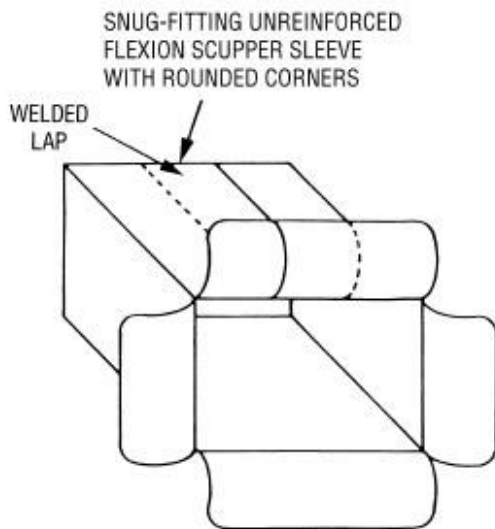

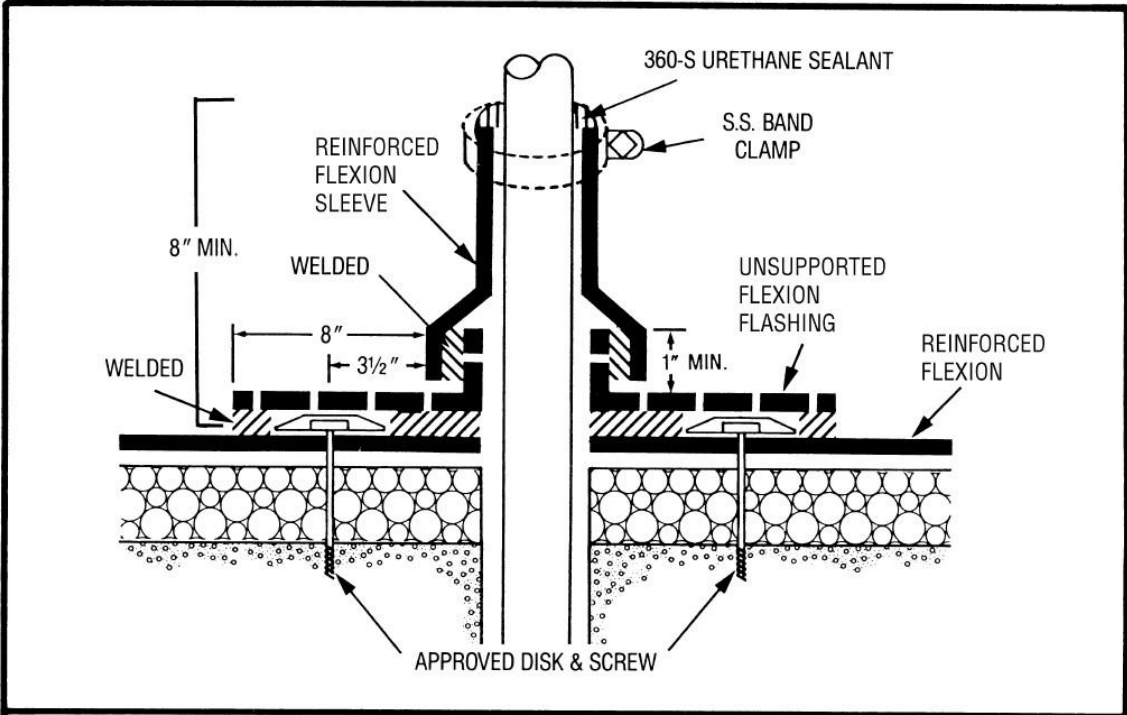

CONKLIN COMPANY, INC.
SHAKOPEE, MN

VENT STACK

DETAIL NUMBER
1-13

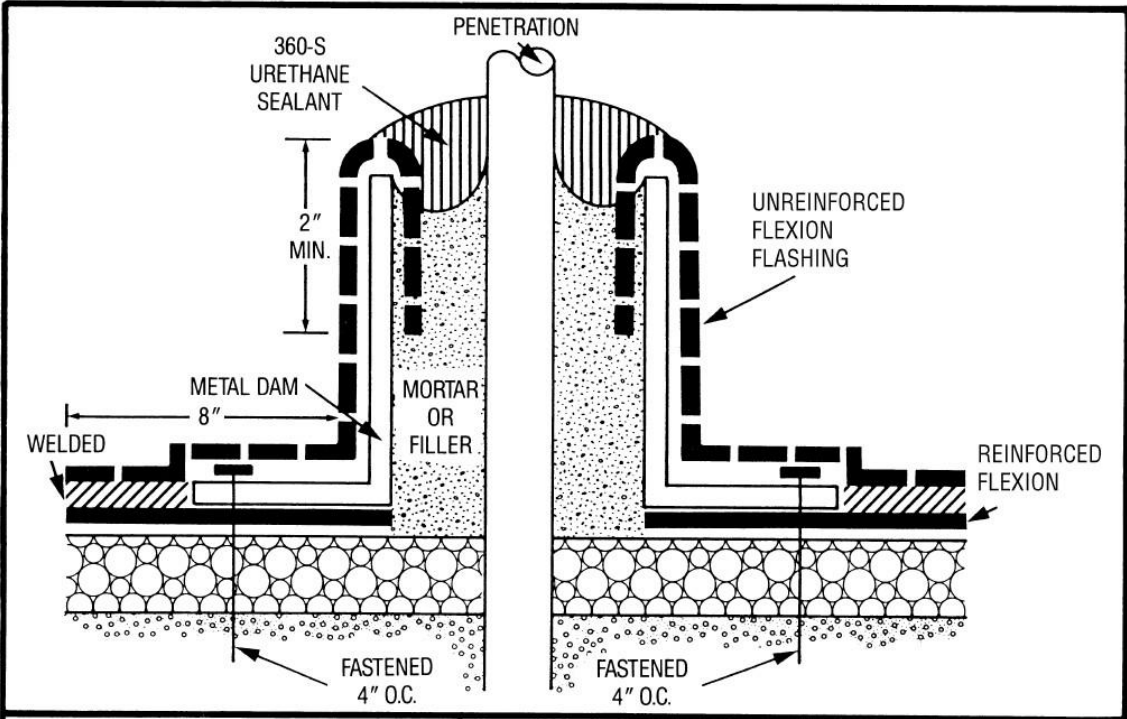

CONKLIN COMPANY, INC.
SHAKOPEE, MN

PITCH POCKET

DETAIL NUMBER
1-14

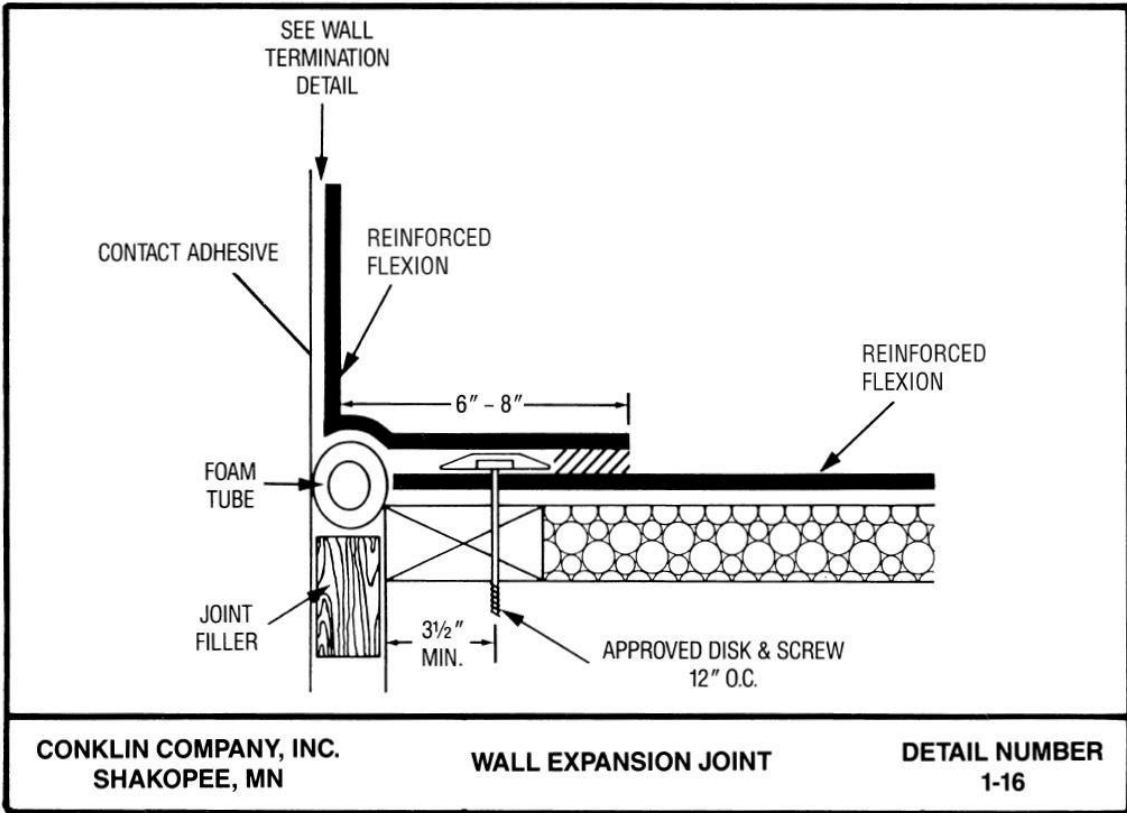
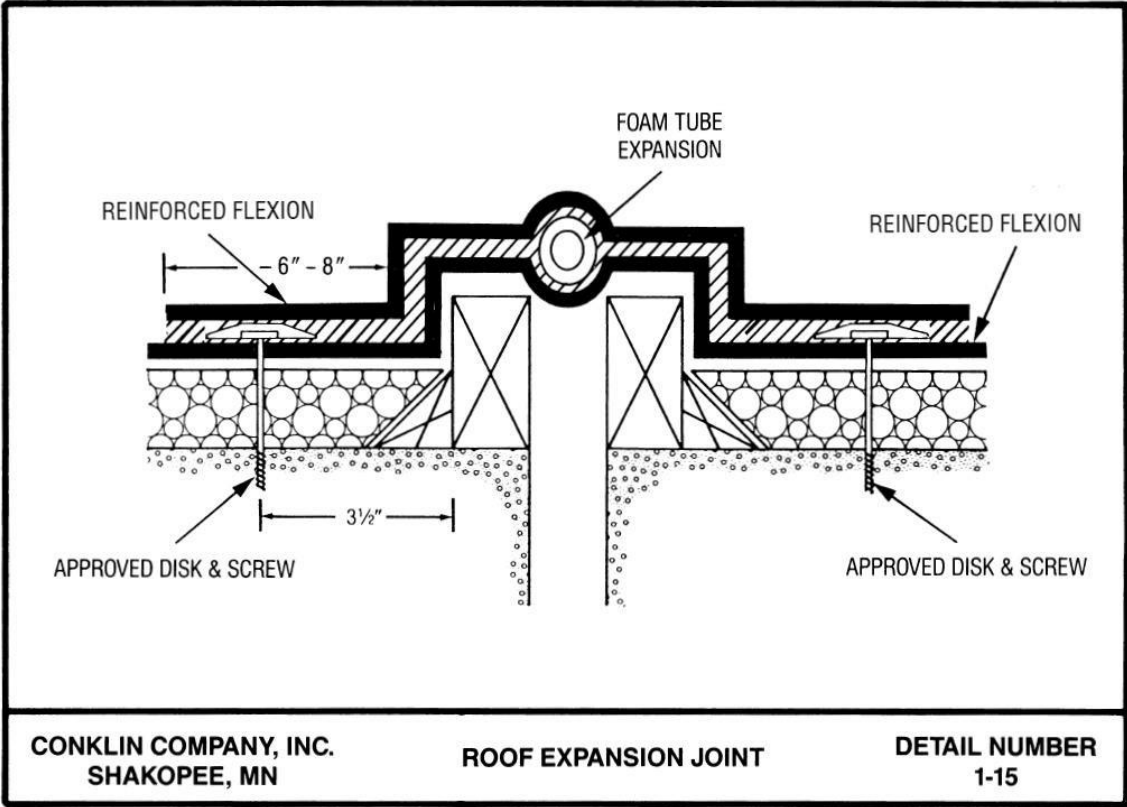

3' x 4'

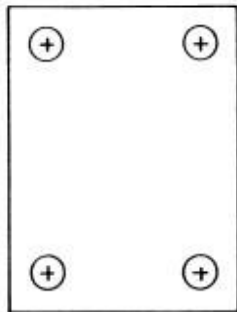

4' x 4'

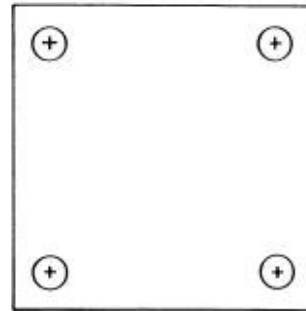

POSITION PLATES SO THAT FASTENERS ARE 6" MINIMUM
FROM EDGES OF BOARD

4 x 8'

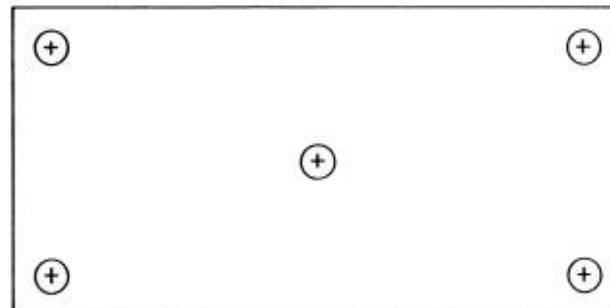

NOTE: THESE FASTENING PATTERNS ARE MINIMUM RECOMMENDATIONS. FACTORY MUTUAL I-60 AND I-90 APPROVED PATTERNS MAY VARY, ACCORDING TO THE INSULATION INVOLVED, AND SHOULD TAKE PRECEDENCE OVER THESE MINIMUMS FOR FM-APPROVED INSTALLATIONS. CONSULT INSULATION MANUFACTURER FOR DETAILS. USE 3" FASTENER PLATES FOR INSULATION FASTENING.

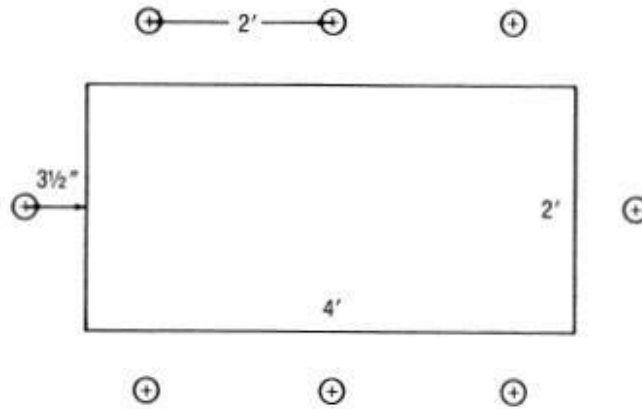

1. PERIMETER OF PENETRATION $(4 + 2) \times 2 = 12$ LINEAL FEET.
2. ALLOW 3 1/2" FROM PERIMETER FOR FASTENER + PLATE SPACING OR 8 FASTENERS AND PLATES.

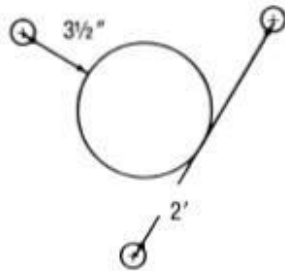

1. MINIMUM OF THREE FASTENERS.
2. THREE FASTENERS SPACED ON 2' CENTERS, UP TO 20" PENETRATION DIAMETER.
3. 3 1/2" FROM CIRCUMFERENCE OF PENETRATION TO C/L OF FASTENER DISC.

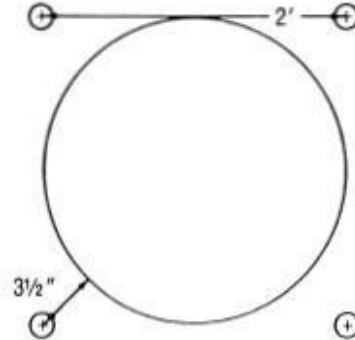

1. FOUR FASTENERS SPACED IN 2' CENTERS, 20" DIAMETER UP TO 30" DIAMETER.
2. 3 1/2" FROM CIRCUMFERENCE OF PENETRATION TO C/L OF FASTENER DISC.

CONKLIN COMPANY, INC.
SHAKOPEE, MN

PENETRATIONS
FASTENING PATTERNS

DETAIL NUMBER
1-18

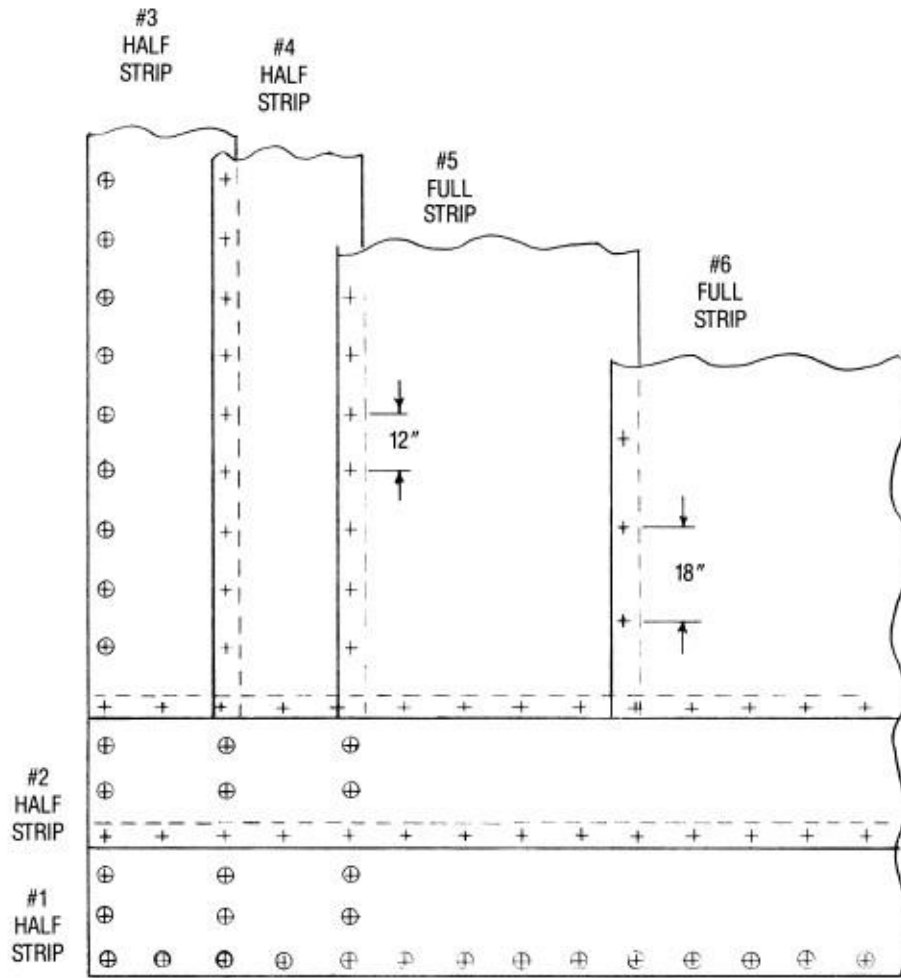

TOP FASTENERS WITH REINFORCED FLEXION FASTENER COVERS (SHOW AS ⊕)

TWO HALF-STRIPS AROUND THE PERIMETER-FASTENERS SPACED A MAXIMUM OF 12" APART.
 FULL STRIPS HAVE FASTENERS SPACED AS INDICATED ON DETAIL #1-23.
 SEQUENCE OF INSTALLATION INDICATED BY NUMBERS.

**THE DRAWING ABOVE DOES NOT REFLECT CURRENT FASTENING REQUIREMENTS BY
 FACTORY MUTUAL. FOR SPECIFIC DETAILS ON FM I-60 AND I-90 WIND UPLIFT RESISTANCE,
 REFER TO TECHNICAL BULLETIN B-6-89-18, UPDATED AUGUST 30, 1993, OR CONTACT
 CONKLIN PRODUCT SERVICES.**

CONKLIN COMPANY, INC.
 SHAKOPEE, MN

DECK PERIMETER FASTENING

DETAIL NUMBER
 1-19

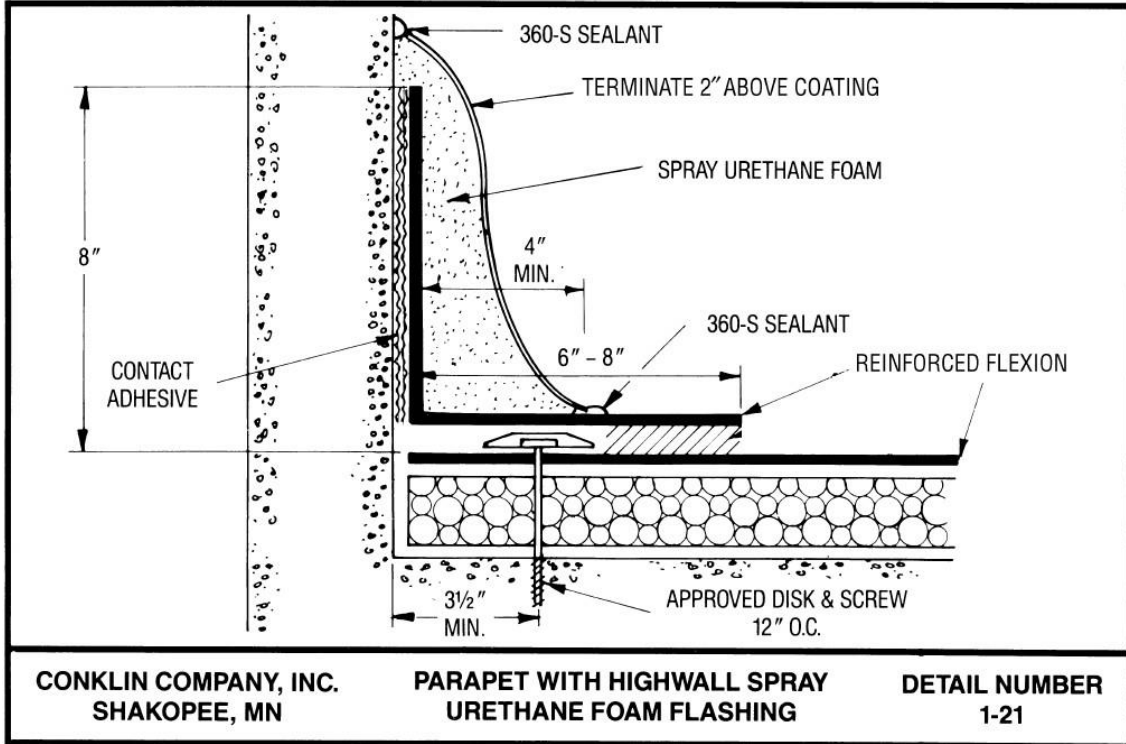
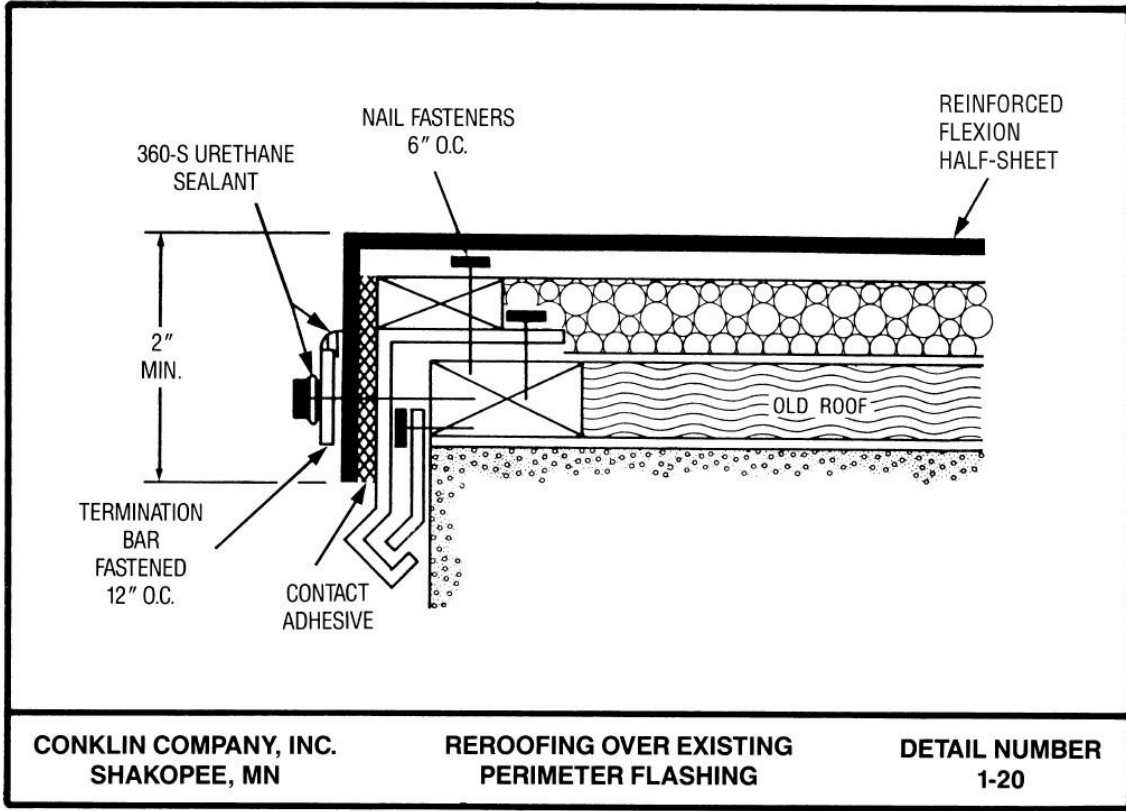

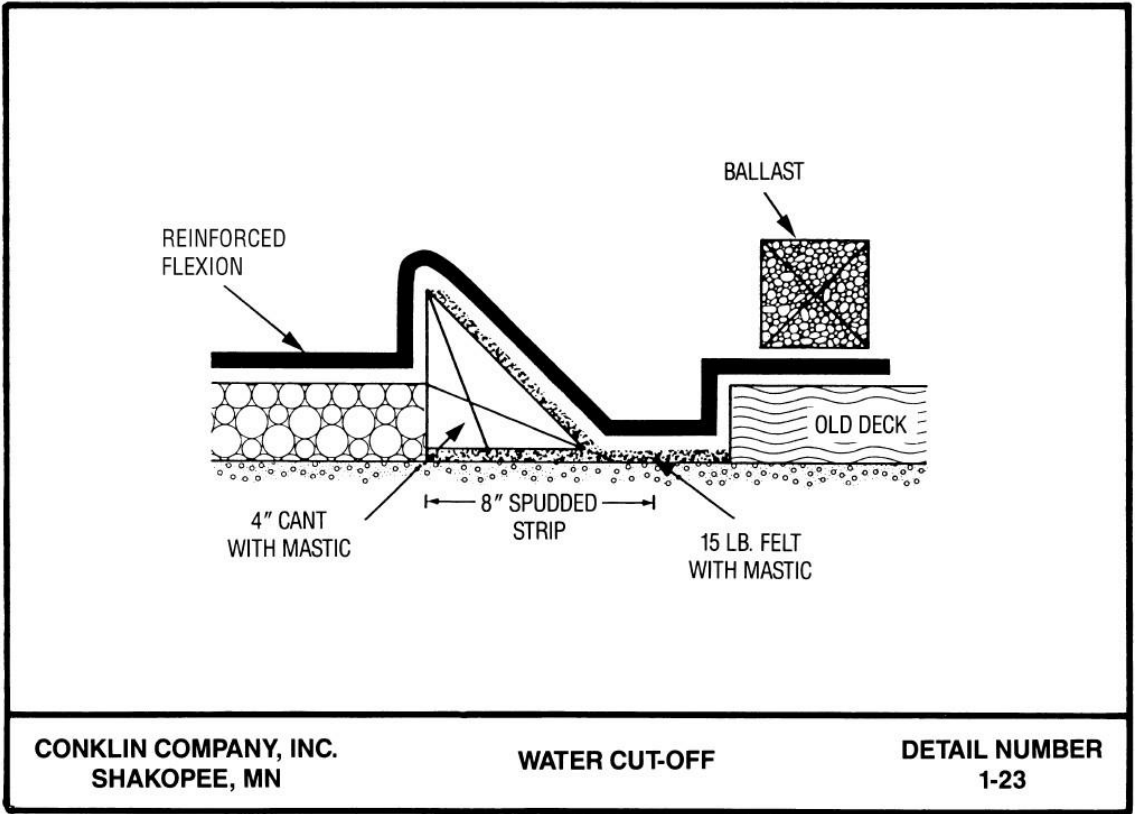
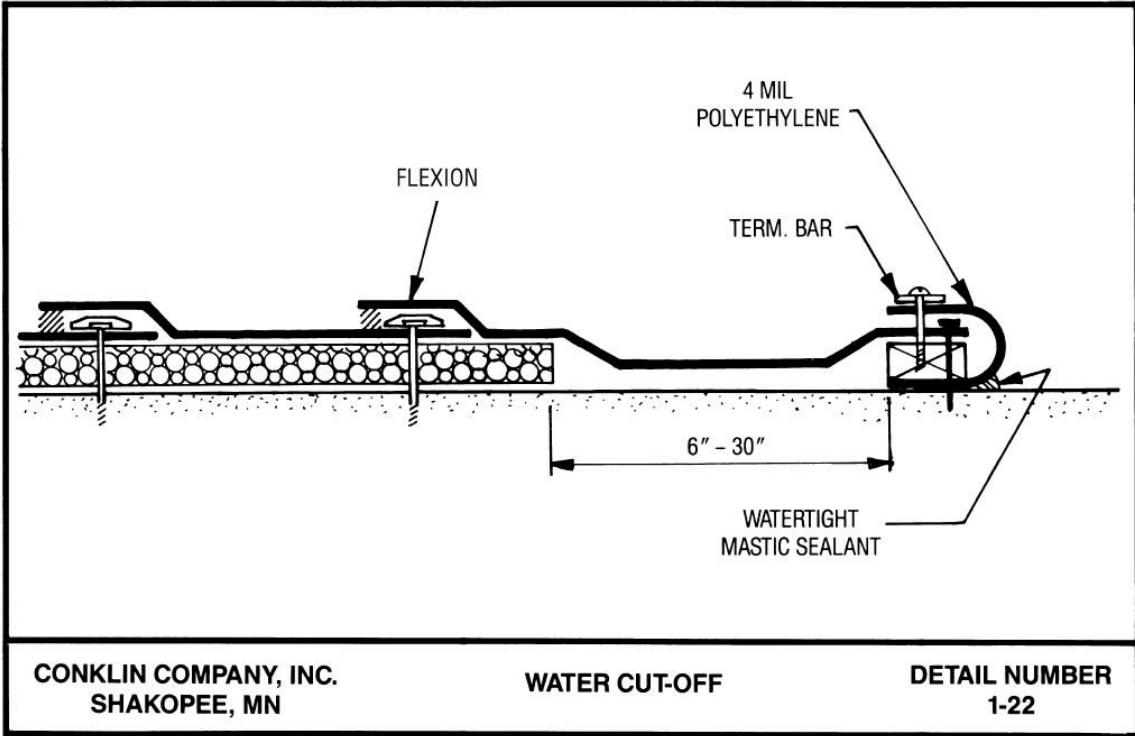

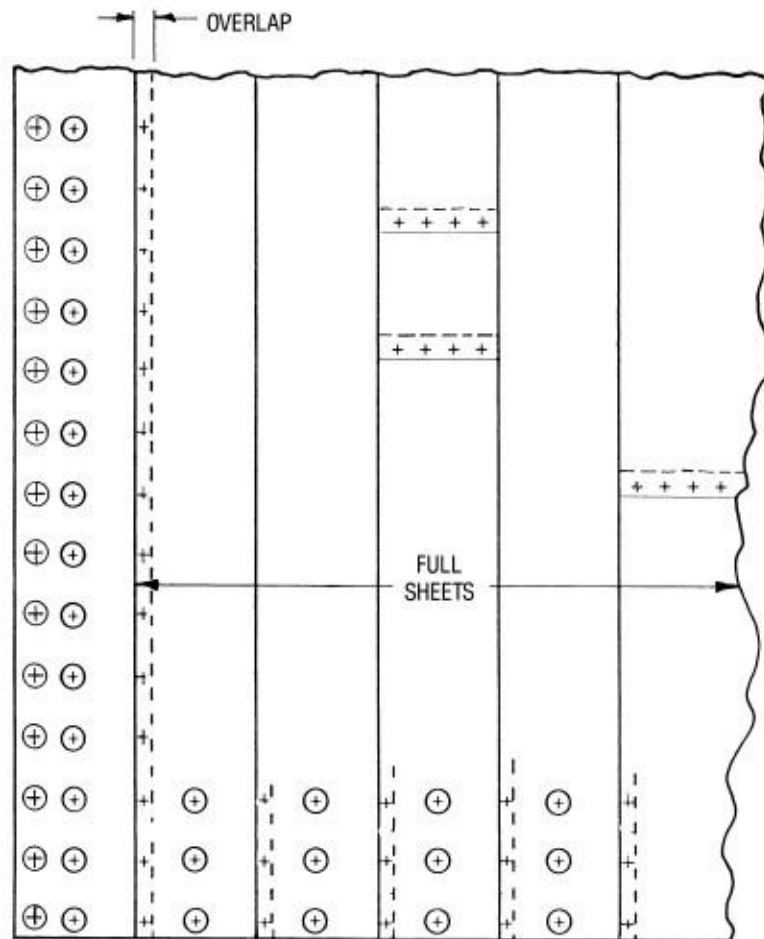

ENDS OF SHEETS ARE LAPPED $4\frac{1}{2}$ " TO ALLOW FOR FASTENING AND WELDING. FASTENERS ARE INSTALLED ON 12" CENTERS, FLUSH WITH BOTTOM EDGE. ALTERNATE PERIMETER FASTENING WHERE HALF-STRIPS ARE NOT USED IS SHOWN. TOP FASTENERS WITH FASTENER COVERS PLACED IN CENTER OF STRIPS AS INDICATED. FASTENERS GENERALLY PLACED ON 12" CENTERS FOR THE FIRST SIX FEET OF STRIPS FROM EDGE. (SHOWN AS ⊕)

CONKLIN COMPANY, INC.
SHAKOPEE, MN

SPLICING AND
PERIMETER FASTENING

DETAIL NUMBER
1-26

MECHANICALLY FASTENED SYSTEM

DECK TYPE	PERIMETER SHEETS	FIELD SHEETS
Metal		
24 gauge	12"	12"
22 gauge	12"	18"
Note: Fasteners must project 1/2" minimum through metal deck.		
Wood		
1 5/8" and 1/2" plywood	12"	12"
5/8" plywood	12"	12"
3/4" plywood	12"	18"
1 1/2" or thicker plank	12"	18"
3/4" - 1 1/2" tongue and groove	12"	18"
1/2" or thicker tongue and groove	12"	18"

Note: Fasteners must project 1/2" minimum through plywood less than 1" thick.
Fasteners must penetrate 1" minimum into plank and tongue and groove.

Concrete		
2500 p.s.i. density	12"	18"

Note: Fasteners must penetrate 1" minimum into concrete.

Other

For lightweight concrete, prestressed concrete, gypsum, tectum or other lightweight decks, contact Conklin Company, Inc. for specific requirements for fasteners and spacing of fasteners.

All projects for warranty will include the proposed fastener spacing when the job approval form is submitted to manufacturer prior to job start-up.

THE CHART ABOVE DOES NOT REFLECT CURRENT FASTENING REQUIREMENTS BY FACTORY MUTUAL. FOR SPECIFIC DETAILS ON FM I-60 AND I-90 WIND UPLIFT RESISTANCE, REFER TO TECHNICAL BULLETIN B-6-89-18, UPDATED AUGUST 30, 1993, OR CONTACT CONKLIN PRODUCT SERVICES.

**CONKLIN COMPANY, INC.
SHAKOPEE, MN**

**SPACING REQUIREMENTS
FOR SEAMS**

**DETAIL NUMBER
1-27**



