



and



Flexion® XL (PVC) and OUTPOST™ (TPO) Prefabricated Accs - Category 3, Custom

Date
 Distributor #
 Distributor Name:
 Phone #
 Email address:

Contact Name:
 Company Name:
 Job Name:
 Job Address:
 System: Flexion® XL OUTPOST™

Please fax or email completed form to: (541) 246-8686 or conklinroof@prefabaccessories.com

Cones-Pipe	#1	#2	#3	#4	#5
(S)plit/Non Split(NS)					
Top					
Bottom					
Height					
Flange					
Quantity					

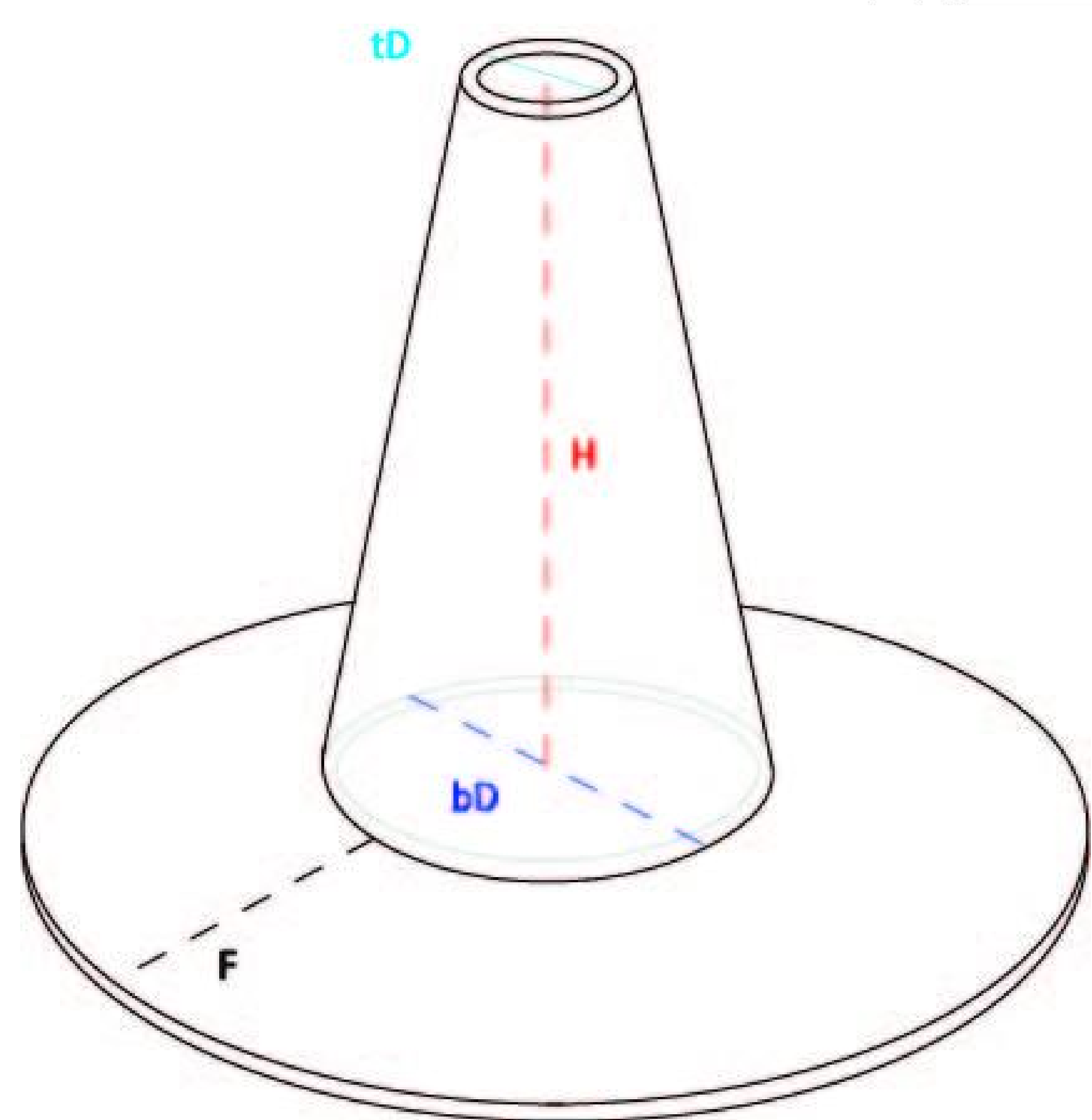

Pipe Wraps	#1	#2	#3	#4	#5
(S)plit/Non Split(NS)					
Inside Diameter					
Height					
Flange					
Quantity					

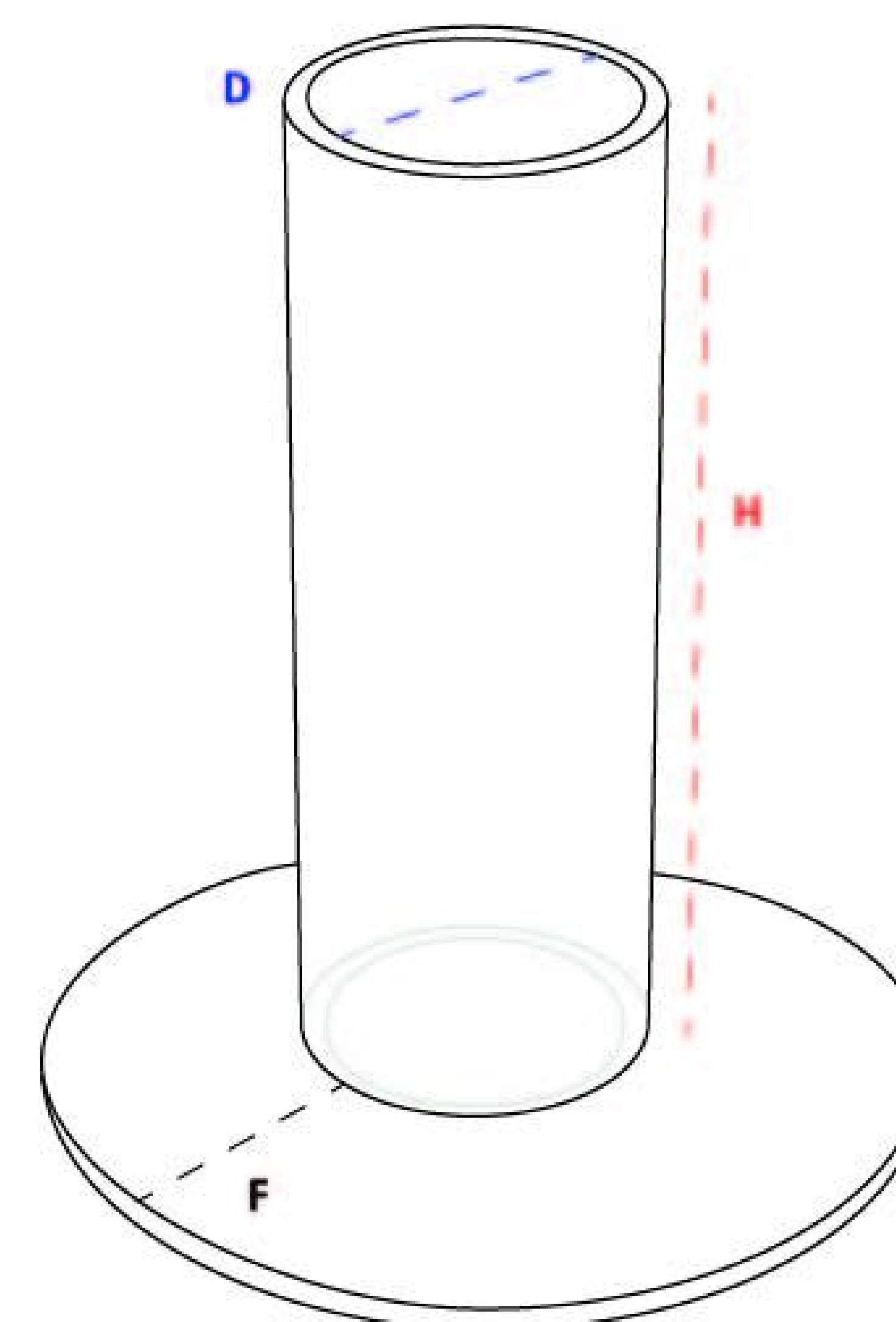

Square Wraps	#1	#2	#3	#4	#5
(W)ood or (M)etal					
(S)plit/Non Split(NS)					
Side 1					
Side 2					
Height					
Flange					
Quantity					

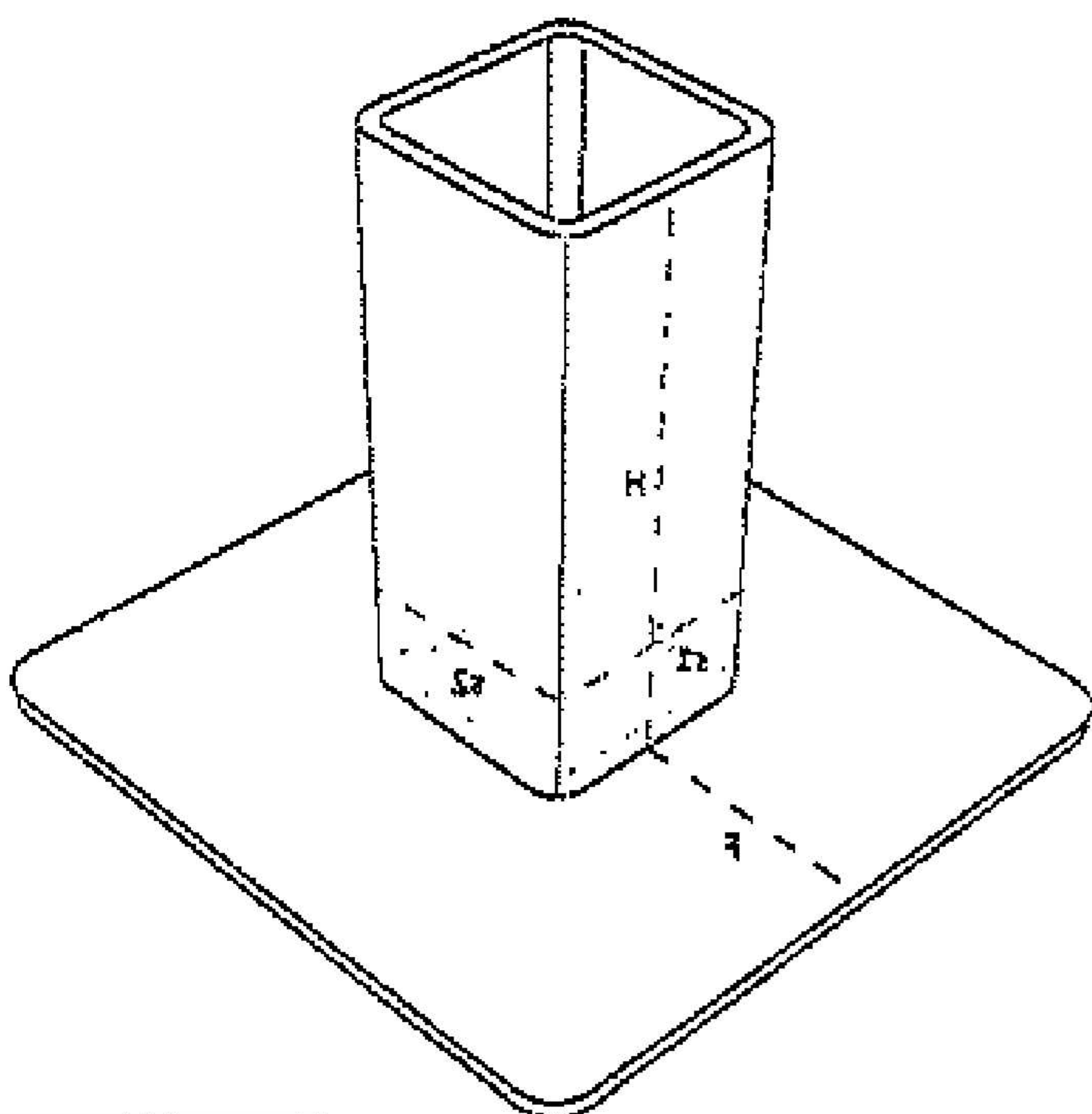

Inside Corner	#1	#2	#3	#4	#5
Height					
Width					
Quantity					
Outside Corner	#1	#2	#3	#4	#5
Height					
Width					
Flange					
Quantity					

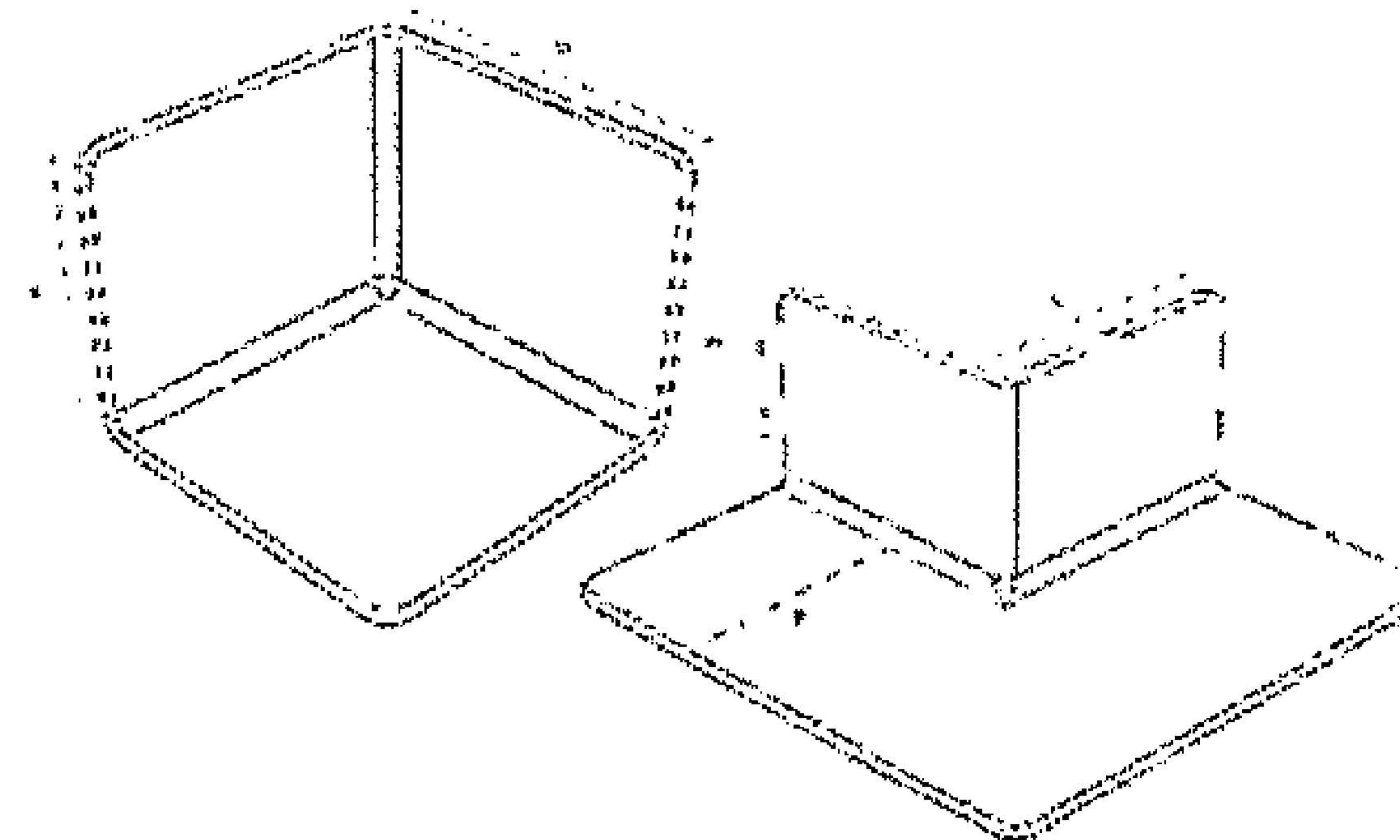



and



Flexion® XL (PVC) and OUTPOST™ (TPO) Prefabricated Accs - Category 3, Custom

Date
 Distributor #
 Distributor Name:
 Phone #
 Email address:

Contact Name:
 Company Name:
 Job Name:
 Job Address:
 System: Flexion® XL OUTPOST™

Please fax or email completed form to: (541) 246-8686 or conklinroof@prefabaccessories.com

Thru Wall	#1	#2	#3	#4	#5
Height					
Width					
Depth					
Flange					
Quantity					

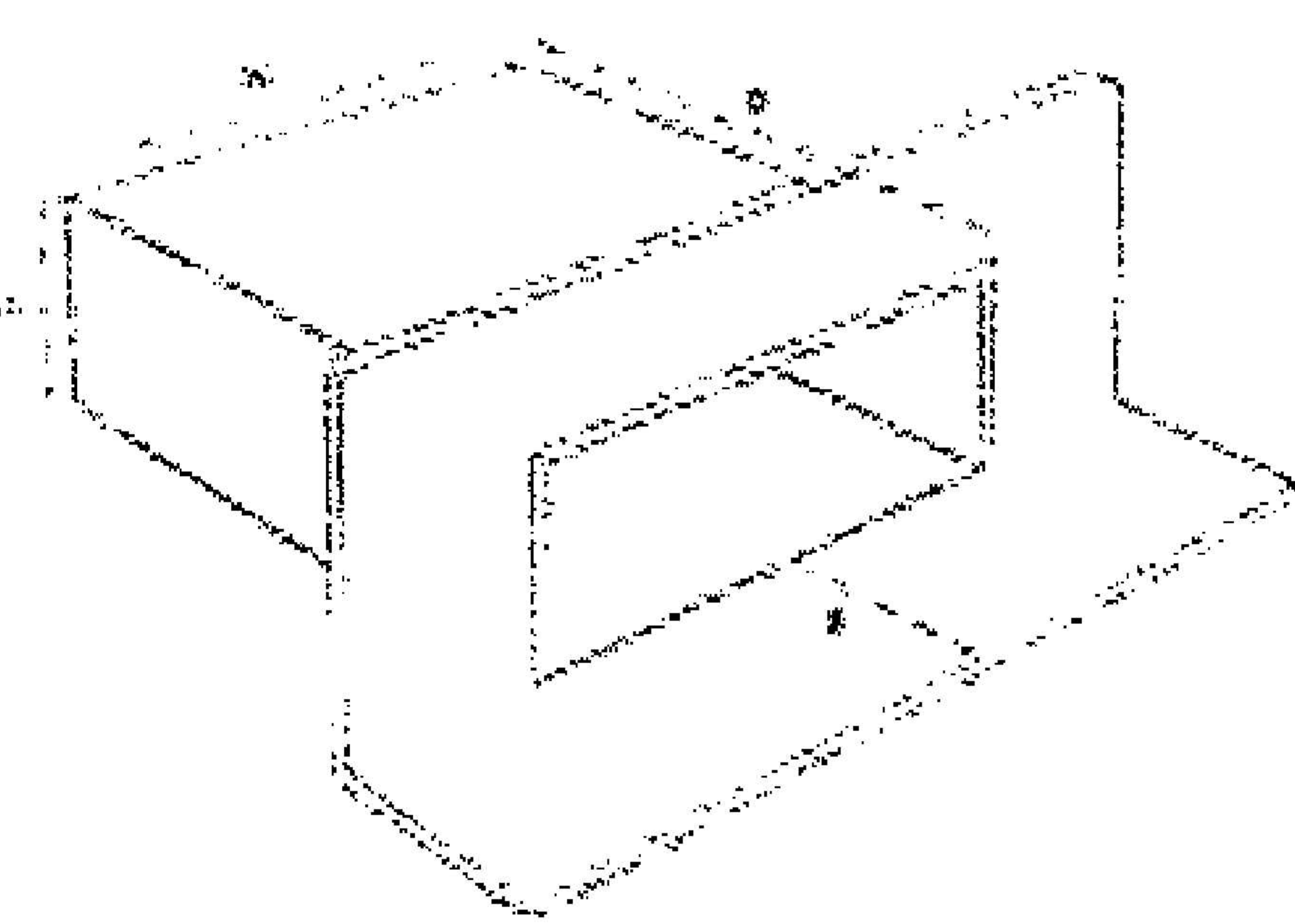

Drop Drain	#1	#2	#3	#4	#5
Outside Diameter					
Width					
Depth					
Flange					
Quantity					

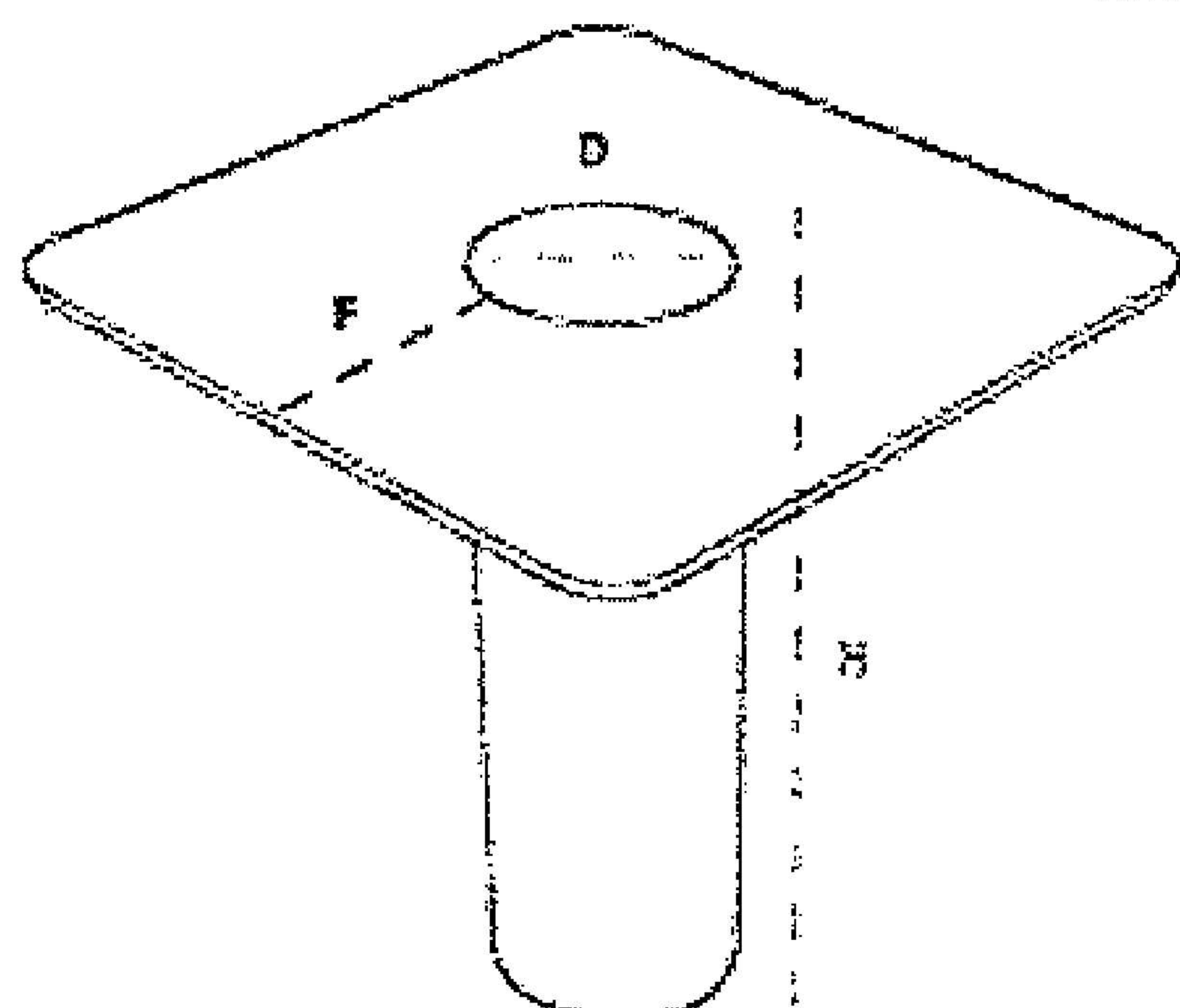

Pitch Pan - Rd	#1	#2	#3	#4	#5
Diameter					
Height					
Flange					
Quantity					

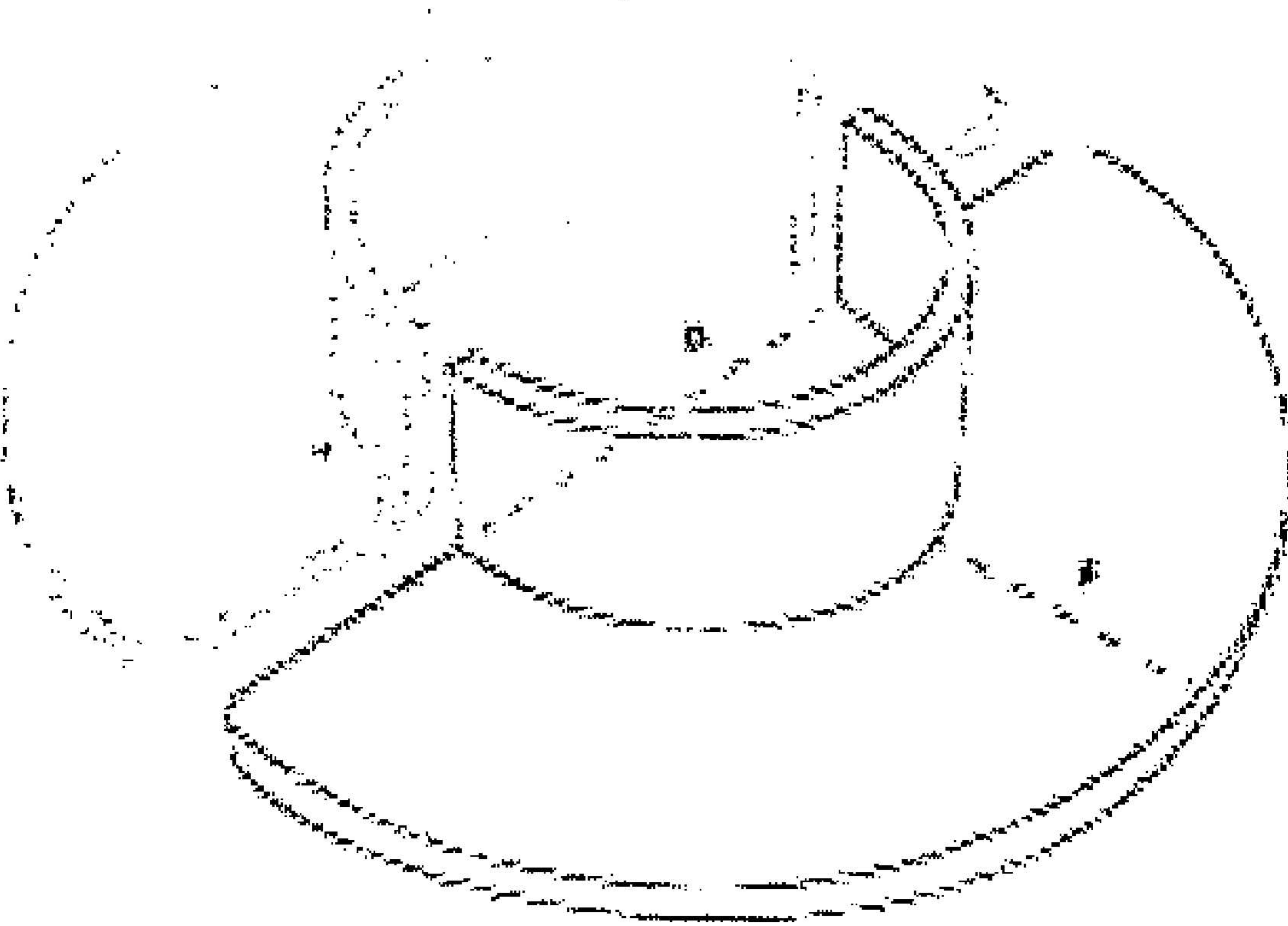

Pitch Pan - Sq	#1	#2	#3	#4	#5
Side 1					
Side 2					
Height					
Flange					
Quantity					

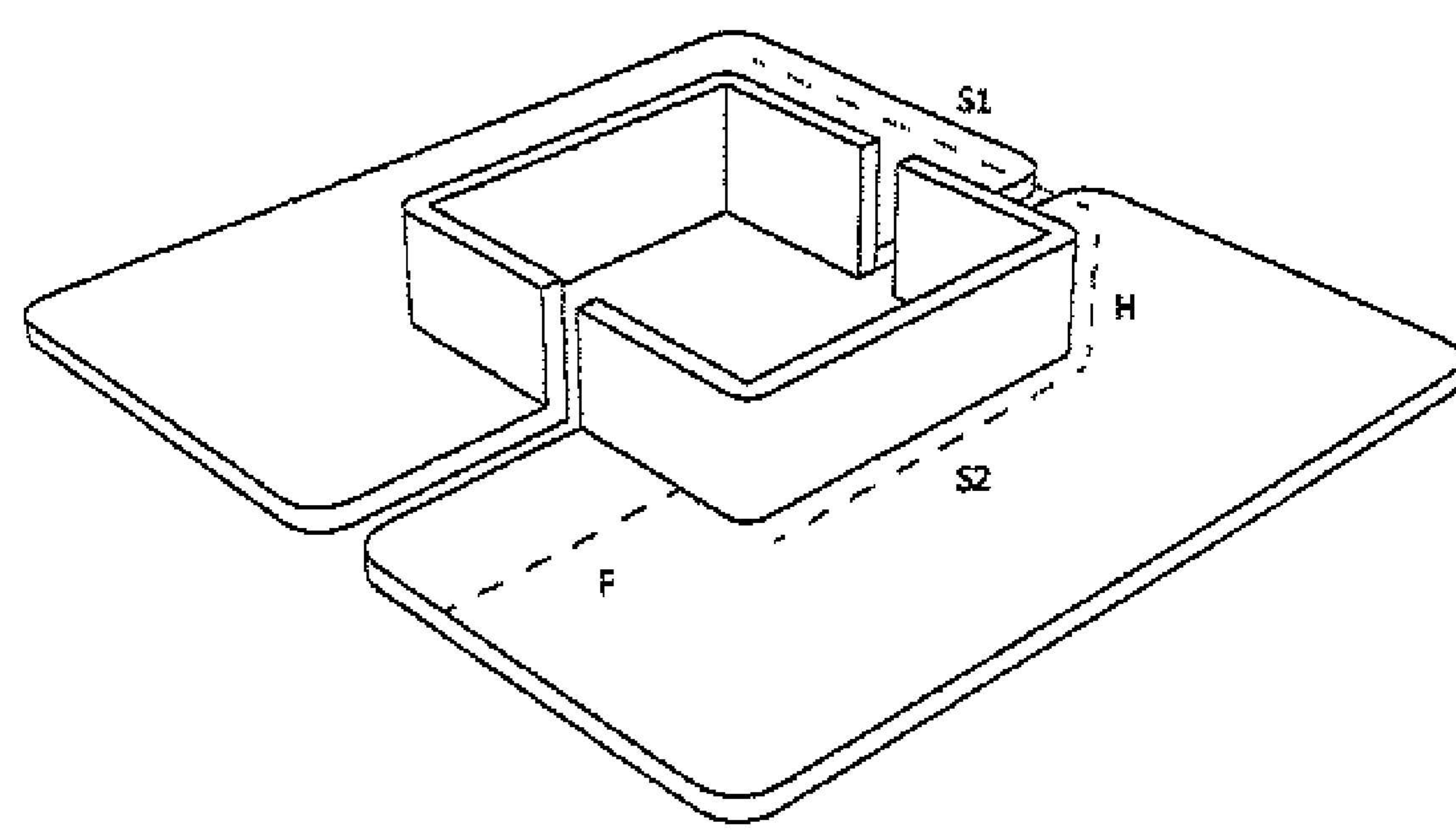



and



Flexion® XL (PVC) and OUTPOST™ (TPO) Prefabricated Accs - Category 3, Custom

Date
 Distributor #
 Distributor Name:
 Phone #
 Email address:

Contact Name:
 Company Name:
 Job Name:
 Job Address:
 System: Flexion® XL OUTPOST™

Please fax or email completed form to: (541) 246-8686 or conklinroof@prefabaccessories.com

Curb Wrap	#1	#2	#3	#4	#5
Height					
Width					
Depth					
Flange					
Quantity					

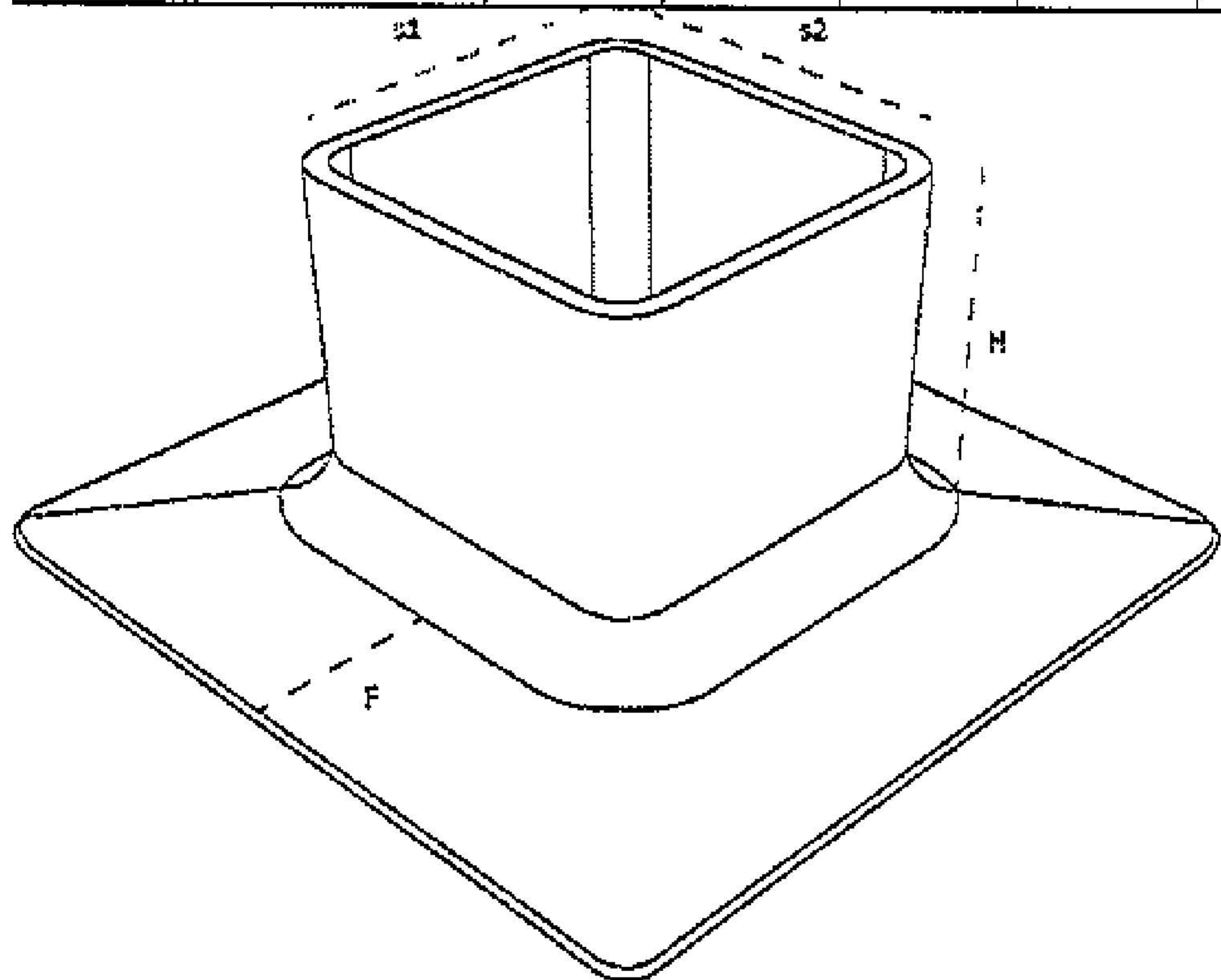

Sleeper	#1	#2	#3	#4	#5
Height					
Width					
Depth					
Flange					
Quantity					

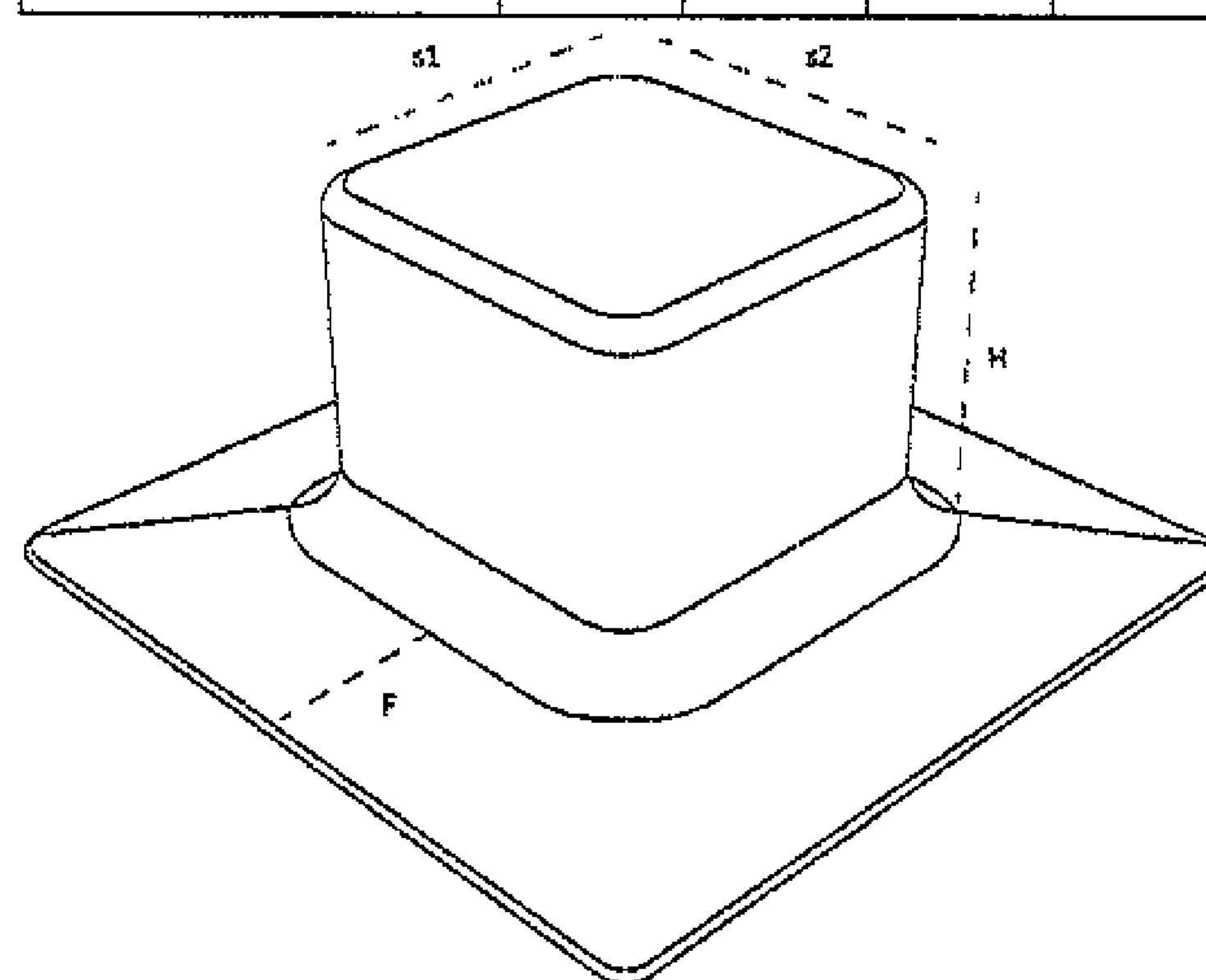

2 Tier Round	#1	#2	#3	#4	#5
Height 1					
Diameter 1					
Height 2					
Diameter 2					
Flange					
Quantity					

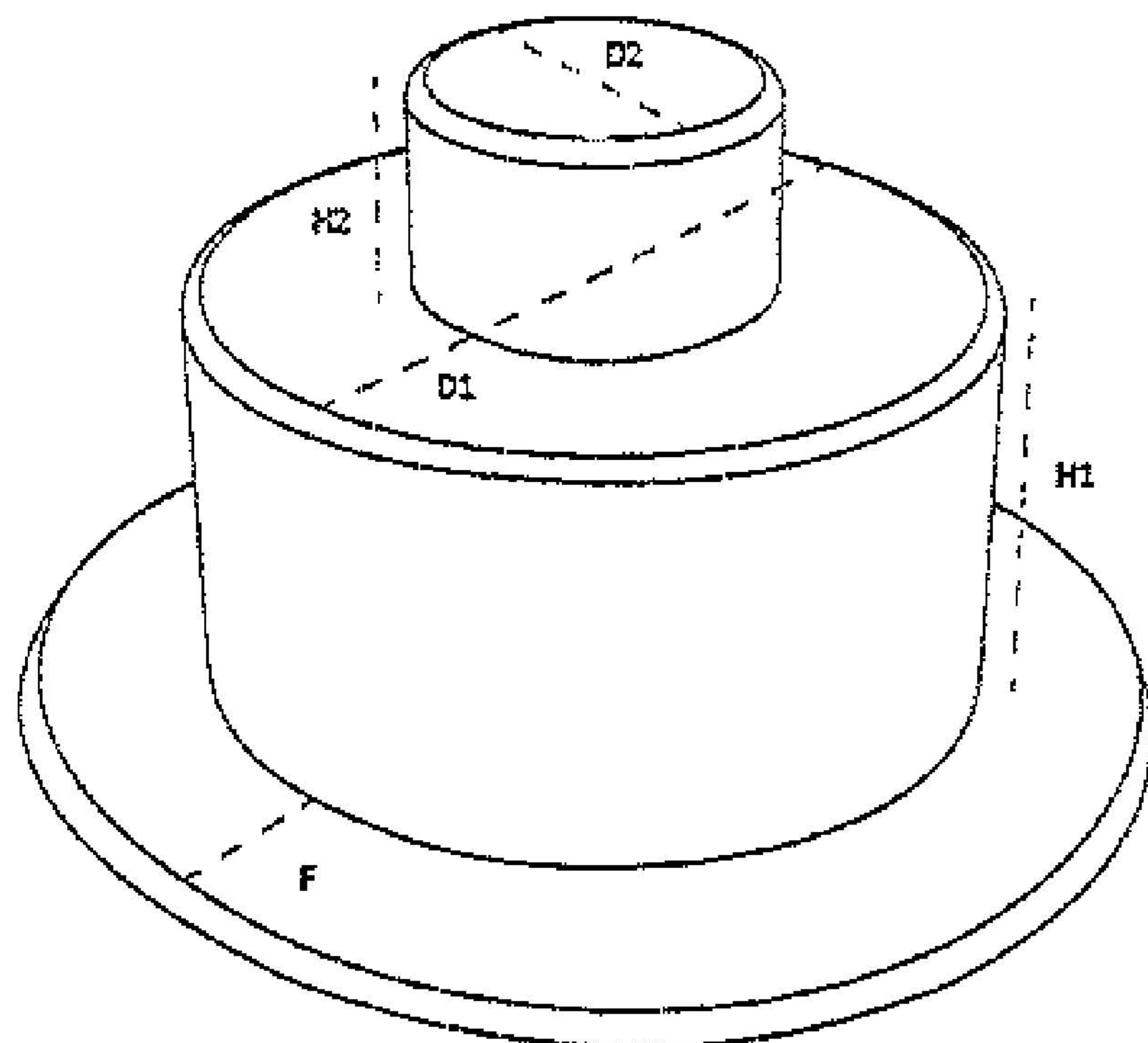

2 Tier Square	#1	#2	#3	#4	#5
Height 1					
Side 1					
Side 2					
Height 2					
Side 3					
Side 4					
Flange					
Quantity					

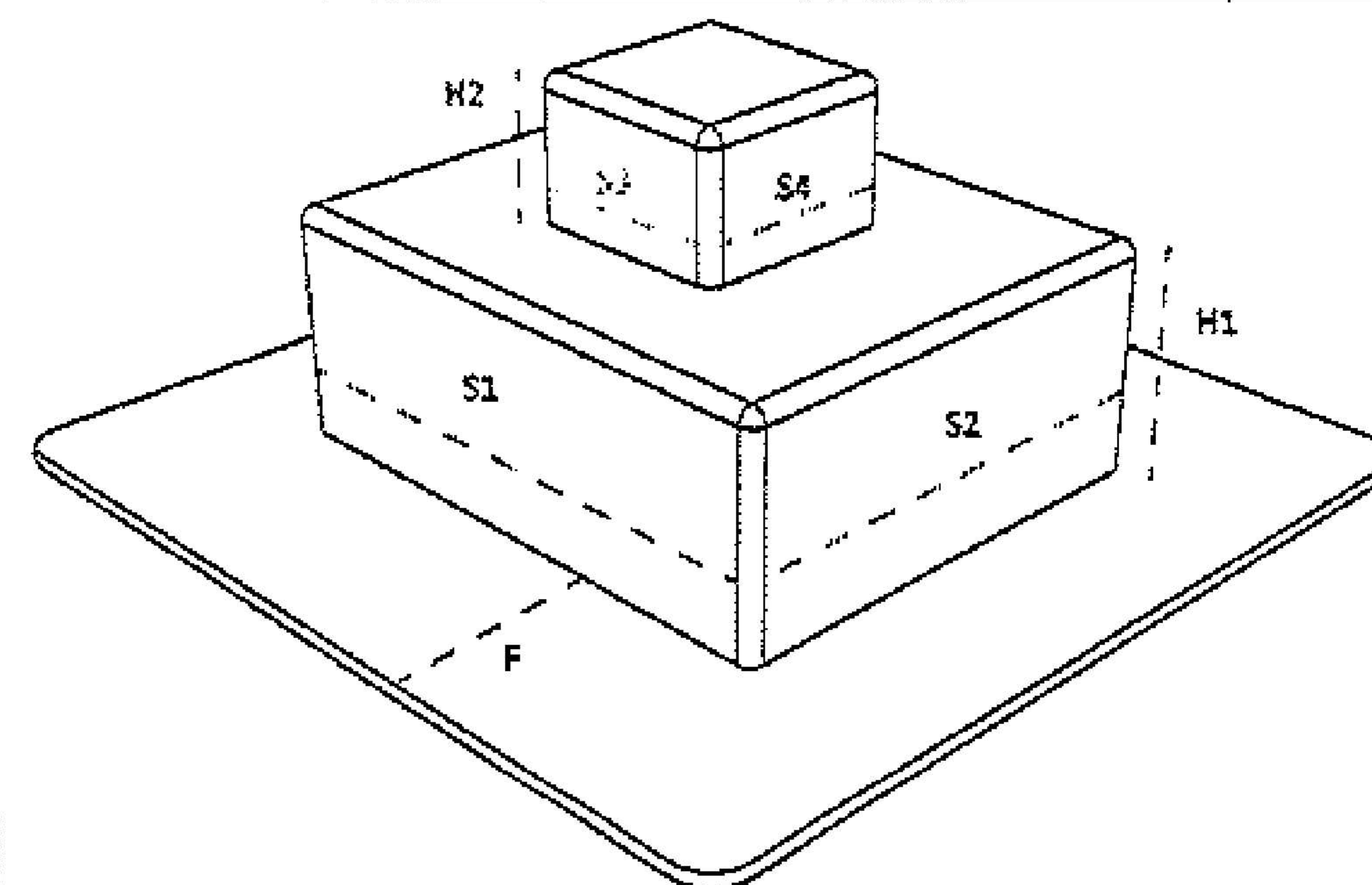



and



Flexion® XL (PVC) and OUTPOST™ (TPO) Prefabricated Accs - Category 3, Custom

Date
 Distributor #
 Distributor Name:
 Phone #
 Email address:

Contact Name:
 Company Name:
 Job Name:
 Job Address:
 System: Flexion® XL OUTPOST™

Please fax or email completed form to: (541) 246-8686 or conklinroof@prefabaccessories.com

Thru Wall	#1	#2	#3	#4	#5	Drop Drain	#1	#2	#3	#4	#5
Height						Outside Diameter					
Width						Width					
Depth						Depth					
Flange						Flange					
Quantity						Quantity					
Pitch Pan - Rd	#1	#2	#3	#4	#5	Pitch Pan - Sq	#1	#2	#3	#4	#5
Diameter						Side 1					
Height						Side 2					
Flange						Height					
Quantity						Flange					



and



Flexion® XL (PVC) and OUTPOST™ (TPO) Prefabricated Accs - Category 3, Custom

Date
Distributor #
Distributor Name:
Phone #
Email address:

Contact Name:
Company Name:
Job Name:
Job Address:
System:

Flexion® XL

OUTPOST™

Please fax or email completed form to: (541) 246-8686 or conklinroof@prefabaccessories.com

Super Custom Item request:

- Please provide drawing with dimensions and material call outs.
- As well as attach any pictures or supporting documents with submitted form email.